

DIMENSIONS AND WEIGHTS

Dimensions are approximate and subject to change. Contact factory for certified dimensions.

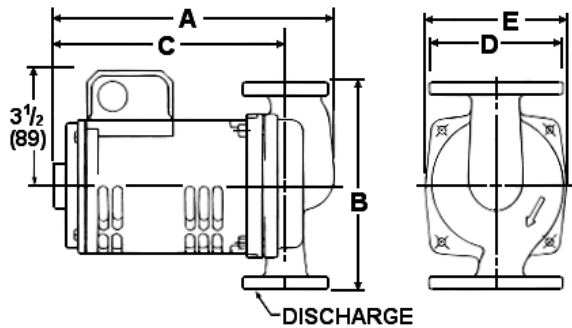

TYPICAL SPECIFICATIONS

The contractor shall furnish and install inline pumps as illustrated on the plans and in accordance with the following specifications:

1. The pumps shall be of the horizontal, permanently lubricated type, specifically designed and guaranteed for quiet operation.
 2. The pumps shall have a steel shaft supported by permanently lubricated, sealed precision ball bearings. The pumps are to be equipped with a water-tight seal to prevent leakage. Mechanical seal faces to be carbon on silicon carbide. The motor shall be non-overloading at any point on the pump performance curve.
 3. The motor shall be of the drip-proof, sealed precision ball-bearing, quiet-operating construction. The permanent split-capacitor motor shall be equipped with thermal overload protection.
 4. Pumps to be suitable for 225°F (107°C) operating temperature at 150 psig (10 bar) working pressure.
- The pumps shall be Bell & Gossett, A Xylem brand. Model No. PL-_____ with a capacity of _____ GPM at _____ feet of head.

PERFORMANCE CHARACTERISTICS CURVES



Xylem Inc.
 8200 N. Austin Avenue
 Morton Grove, IL 60053
 Phone: (847)966-3700
 Fax: (847)965-8379
 www.xylem.com/bellgossett

Bell & Gossett is a trademark of Xylem Inc. or one of its subsidiaries.
 © 201 Xylem Inc.