



Series 100
Series HV
Series PR



Series 2"

Iron & Bronze Booster Pumps

INSTALLER: PLEASE LEAVE THIS MANUAL FOR THE OWNER'S USE.

DESCRIPTION

Bell & Gossett Booster Pumps feature oil lubricated sleeve bearings, a carbon/ceramic seal and a noise dampening spring coupler. Bell & Gossett Booster Pump motors are designed specifically for quiet operation and are built with thermal protection and drip-proof construction. The motor is non-over-loading at any point on the pump curve.

This pump is nonsubmersible, for indoor use only.

PUMP APPLICATION

Bell & Gossett Pumps may be used for water circulating applications in hydronic, solar and chilled water systems. Bell & Gossett recommends that bronze constructed pumps be used for pumping potable water. For other applications contact your local Bell & Gossett Representative. Note that some local codes require using a check valve in the supply line when recirculating potable water.

It has not been investigated, nor is it intended for use in swimming pool and marine areas.

OPERATIONAL LIMITS

These pumps are designed to pump liquids compatible with their iron or bronze body construction. Unless special provisions have been made by Bell & Gossett, the operational limits for Series 100, HV, PR and 2" Pumps are listed below.

Do not exceed these values.

Maximum Working Pressure: 125 psi
Maximum Operating Temperature: 225°F
Electrical Rating: 115V, 60 Hz, 1PH

Motors with special electrical characteristics are available on request. Contact your local Bell & Gossett Representative for details.



SAFETY INSTRUCTIONS

This safety alert symbol will be used in this manual and on the pump instructions decal to draw attention to safety related instructions. When used, the safety alert symbol means ATTENTION! BECOME ALERT! YOUR SAFETY IS INVOLVED! FAILURE TO FOLLOW THE INSTRUCTIONS MAY RESULT IN A SAFETY HAZARD.

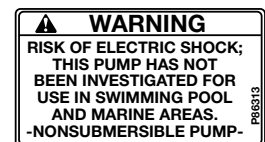

Your Booster Pump should have these warning labels affixed near the conduit box cover. If these warnings are missing or illegible, contact your local Bell & Gossett Representative for replacement labels.

SAFETY REQUIREMENTS

MECHANICAL SAFETY

 **WARNING: EXCESSIVE SYSTEM PRESSURE HAZARD**

The maximum working pressure of the pump is listed on the nameplate – DO NOT EXCEED THIS PRESSURE. Failure to follow these instructions could result in serious personal injury, death and/or property damage.

 **WARNING: EXCESSIVE PRESSURE HAZARD – VOLUMETRIC EXPANSION**

The heating of water and other fluids causes volumetric expansion. The associated forces may cause failure of system components and release high temperature fluids. This can be prevented by installing properly sized and located expansion tanks and pressure relief valves. Failure to follow these instructions could result in serious personal injury, death and/or property damage.

THERMAL SAFETY

 **WARNING: EXTREME TEMPERATURE HAZARD**

If the pump, motor, or piping are operating at extremely high or low temperature, guarding or insulation is required. Failure to follow these instructions could result in serious personal injury, death and/or property damage.

 **WARNING: HOT WATER HAZARD**

When disassembling a gasket joint, always use a new gasket upon reassembly. NEVER RE-USE OLD GASKETS. Failure to follow these instructions could result in serious personal injury, death and/or property damage.

ELECTRICAL SAFETY

 **WARNING: ELECTRICAL SHOCK HAZARD**

Electrical connections are to be made by a qualified electrician in accordance with all applicable codes, ordinances and good practices. Failure to follow these instructions could result in serious personal injury, death and/or property damage.

 **WARNING: ELECTRICAL OVERLOAD HAZARD**

Three phase motors must have properly sized heaters to provide overload and under voltage protection. Single phase motors have built-in overload protectors. Failure to follow these instructions could result in serious personal injury, death and/or property damage.

 **WARNING: ELECTRICAL GROUNDING HAZARD**

Adequate electrical grounding is required for the safe operation of B&G Pumps. The use of grounded metal conduit assures this requirement. If the means of connection to the supply-connection box (wiring compartment) is other than grounded metal conduit, ground the pump back to the service by connecting a copper conductor at least the size of the circuit conductors supplying the pump to the green grounding screw provided within the wiring compartment. Failure to follow these instructions could result in serious personal injury, death and/or property damage.

 **WARNING: RISK OF ELECTRIC SHOCK**

Do not install this pump in swimming pool or marine areas. Failure to follow these instructions could result in serious personal injury, death and/or property damage.

 **WARNING:**

This product can expose you to chemicals including Lead, which is know to the State of California to cause cancer and birth defects or other reproductive harm. For more information go to: www.P65Warnings.ca.gov.

REMOVAL OF THE PUMP FROM EXISTING SYSTEM FOR REPLACEMENT

 **WARNING: ELECTRICAL SHOCK HAZARD**

Disconnect and lockout the power before servicing. Failure to follow these instructions could result in serious personal injury or death.

1. Close the valves on the suction and discharge sides of the pump. If no valves have been installed, it may be necessary to drain the system.

 **WARNING: HOT WATER HAZARD**

Before draining the system, allow water to cool to 100°F max. open the drain valve (take precautions against water damage) and leave the drain valve open until servicing is complete. Failure to follow these instructions could result in serious personal injury, death and/or property damage.

 **WARNING: ELECTRICAL SHOCK HAZARD**

Be certain the electrical power is not present at the motor leads before continuing. Failure to follow these instructions could result in serious personal injury or death.

2. Loosen the conduit box cover screw and remove the cover.

 **WARNING: UNEXPECTED START-UP HAZARD**

Single phase motors are equipped with automatic reset overload protectors. The pump can restart without warning. Disconnect and lockout power before servicing. Failure to follow these instructions could result in serious personal injury, death and/or property damage.

3. Disconnect the electrical supply lines to the pump.

 **WARNING: HIGH PRESSURE HAZARD**

Pressure may be present in the pump body. This pressure can be relieved by loosening the flange bolts and shifting the pump assembly slightly to allow the pressurized water to escape. Failure to follow these instructions could result in serious personal injury or death.

4. Remove the flange bolts and remove the pump from the piping.

PUMP INSTALLATION

CAUTION: PROPERTY DAMAGE HAZARD

It is not advisable to install circulators in an attic or upper floor over finished living space. If the circulator must be installed over head, or over expensive equipment, provide adequate drainage in the event of leakage. Failure to follow these instructions could result in property damage.

PUMP LOCATION

Bell & Gossett Booster Pumps should be installed where there will be sufficient room for future inspection, maintenance and service. It is highly recommended that service valves (shut-off) also be installed on each side of circulator pumps to facilitate servicing or replacing the pump without draining the system.

IMPORTANT: In closed systems, do not install and operate Bell & Gossett pumps, 3D valves, suction diffusers, etc., without properly sized safety and control devices. Such devices include the properly sized and located pressure relief valves, expansion tanks and pressure, temperature, and flow controls. If the system is not equipped with these devices, consult the responsible engineer or architect before operating.

PUMP SUPPORTING AND PIPING

Install the suction and discharge flanges on the pipe ends using PTFE tape sealer or high quality thread sealant. Minimize strain on the pump by supporting the suction and discharge piping with pipe hangers near the pump. Line up the vertical and horizontal piping so that the bolt-holes in both the pump and pipe flanges are aligned. **DO NOT ATTEMPT TO SPRING THE SUCTION OR DISCHARGE LINES INTO POSITION. THIS MAY RESULT IN UNWANTED STRESS IN THE PUMP BODY, FLANGE CONNECTIONS AND/OR PIPING.** The code for pressure piping, ANSI B31.1, lists types of supports for various applications.

Ordinary wire or band hangers are not adequate to maintain alignment. It is very important to provide strong, rigid support for the suction and discharge lines.

IMPORTANT: Do not support the pump by its power pack. To function properly, the motor power pack must not be strained.

MODE OF DISCHARGE

Bell & Gossett Pumps can be installed to discharge up, down, left or right. The oiling ports must always be in the twelve o'clock position (on top) with motor and bearing assembly in a horizontal position. **THE ARROW ON THE PUMP BODY MUST POINT IN THE DIRECTION OF THE FLOW.** If it becomes necessary to change the mode of discharge, refer to B&G Instruction Manual HS-105-SM for specific instructions in removing the motor and bearing assembly from the pump body.

OIL PORTS

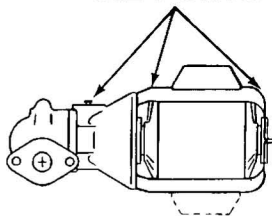

NOTE: The position of the conduit box is determined by the model of the motor used. The oiling ports must always be in the up position.

PUMP FLANGES

New Bell & Gossett flanges gaskets must be installed between the flanges of the pump body and suction and discharge pipes. The gaskets should be clean and grease-free; old gaskets should never be reused.

WARNING: HOT WATER HAZARD

When disassembling a gasketed joint, always use a new gasket upon reassembly. **NEVER RE-USE OLD GASKETS.** Failure to follow these instructions could result in serious personal injury, death and/or property damage.

WARNING: HOT WATER HAZARD

Make sure that each flange gasket remains seated in the flange groove during and after installation. Failure to follow these instructions could result in serious personal injury, death and/or property damage.

Apply torque in even increments to both flange bolts until the value listed in the table below is reached. Both the suction and

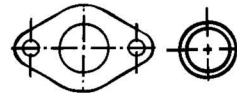

Pump Series	100 With Full Face Flange Gasket*	100 With Ring Flange Gasket	PR	HV	2"
Bolt Torque	150-180 in. lbs. 12.5-15 ft. lbs.	96-132 in. lbs. 8-11 ft. lbs.	96-132 in. lbs. 8-11 ft. lbs.	96-132 in. lbs. 8-11 ft. lbs.	96-132 in. lbs. 8-11 ft. lbs.
Full turns of the nut from finger tight	1-1/4	1	1	3/4	3/4

* No longer used.

WARNING: WATER LEAKAGE HAZARD

To prevent leakage, make certain that the flange bolts have been adequately torqued. Failure to follow these instructions could result in serious personal injury and/or property damage.

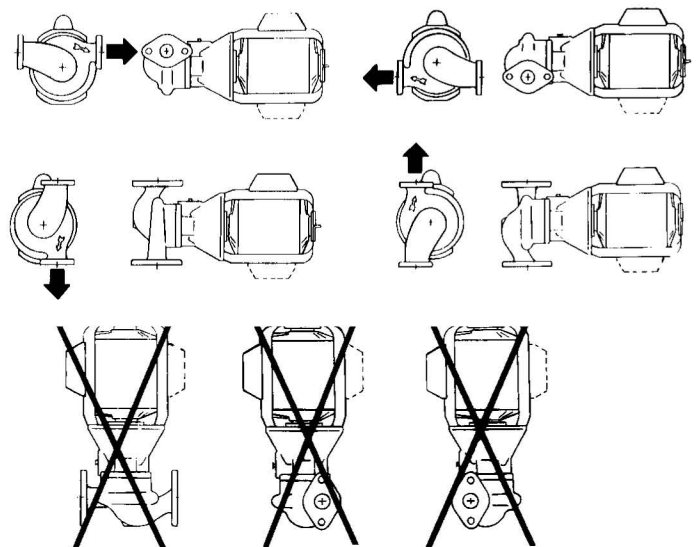

WIRING INSTRUCTIONS



WARNING: ELECTRICAL SHOCK HAZARD

Disconnect and lockout the power before making electrical connections. Failure to follow these instructions could result in serious personal injury or death.

1. Remove the screws securing the conduit box cover (wiring compartment) and lift off the cover. Attach the appropriate size connector to the hole in the side of the conduit box.
2. Using a minimum size 14 AWG copper electrical wire (refer to your local code for wiring restrictions), wire the motor to a 115 volt, 60 hertz, single phase power source.

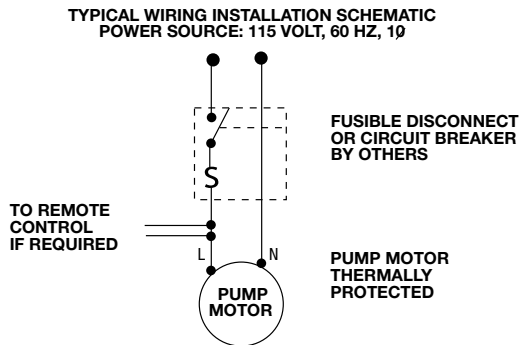

3. Connect the ground wire to the green screw inside the conduit box.

NOTE: Single phase motors are protected with inherent overheating devices and do not require external overload protection.

NOTE: If a motor with special characteristics is selected, the electrical rating of the power source must be the same as that of the motor.



WARNING: ELECTRICAL SHOCK HAZARD

Be certain that all connections are secure and the conduit box cover is closed before electrical power is connected. Failure to follow these instructions could result in serious personal injury, death and/or property damage.

OPERATIONAL INSTRUCTIONS

SYSTEM PREPARATION

Prior to pump start up, closed heating and cooling systems should be flushed with clean water and drained. The system should then be filled with clean water having a PH between 7 and 9.

LUBRICATION

Although the new B&G pumps are test run at the factory, they must be lubricated thoroughly before being placed in operation. Bell & Gossett supplies a high quality lubricant specifically for this purpose which can be purchased from any B&G Representative (Part No. L23401). Proper lubrication procedures are as follows:

1. **PUMP BEARINGS** – Fill the bearing frame according to the oiling instructions decal. At the time of installation, add approximately 1 oz. of B&G #20 weight non-detergent oil. An SAE 20 (non-detergent) or 10W-30 oil may be substituted. Re-lubrication is required at the start of each heating season, or every three months for continuous service. Re-lubricate with 1 teaspoon of oil. More frequent lubrication may be required under adverse conditions such as high ambient temperatures. Less frequent lubrication is required if oil overflows from the reservoir.
2. **MOTOR BEARINGS** – Lubricate through the two motor oil cups according to the lubrication decal. At the time of installation the motor bearings use approx. 12 drops each. At re-lubrication intervals fill each motor bearing with approx. 6-8 drops. More or less frequent re-lubrication may be required depending on the installation conditions.

NOTE: Over-oiling can cause motor mount deterioration and may cause spillage onto surrounding surfaces. Deteriorated motor mounts will lead to misalignment and excessive coupler wear.



CAUTION: SEAL DAMAGE HAZARD

Do not run the pump dry – seal damage may occur. Failure to follow these instructions could result in moderate personal injury and/or property damage.

PRIMING AND STARTING

Do not run B&G circulator pumps dry. Before starting, the pump must be filled with water. Air should be vented from the system by means of a system air vent or by an alternate method.

SERVICE INSTRUCTIONS

1. Keep the pump and motor properly lubricated.
2. If the system is to be exposed to freezing temperatures, drain the pump.

PERIODIC INSPECTION

Inspect the pump regularly for leaking seals, worn gaskets, and loose or damaged components. Replace or repair as required.

ADDITIONAL PUMP REPAIR

Refer to the following manuals for additional repair instructions for Bell & Gossett Iron & Bronze Booster Pumps:

Coupler & Motor Mount Replacement#S15900, Rev. D
Booster Pump Service Manual#HS-105-SM, Rev. 3



Xylem Inc.
8200 N. Austin Avenue
Morton Grove, Illinois 60053
Phone: (847) 966-3700
Fax: (847) 965-8379
www.xylem.com/bellgossett