



Hydronic Heating and Plumbing Products





Intelligent, efficient and complete system solutions from the most trusted name in the industry-Bell & Gossett

Bell & Gossett leads the industry with a complete system offering that delivers uncompromising quality and dependability. Efficient B&G products are at the heart of smart system solutions that provide customers with reliable, energy saving solutions backed by over 100 years of experience and innovation.

ESP-Systemwise™ is the industry's only comprehensive system selection tool providing you the ability to choose all system components from a single integrated tool, saving you time and ensuring the most efficient hydronic system design. You get fast, precise equipment selection, pump performance curves, job specific submittals and other technical data.

Bell & Gossett representatives are the industry's most experienced HVAC professionals with a wealth of technical expertise and practical know how. In addition to expert system and product application assistance they also maintain a wide product inventory warehoused locally for immediate delivery of your ordered equipment and parts anywhere in the country.



The Most Complete Line of Hydronic Heating and Plumbing Products.

All from a Single Source - Bell & Gossett.



Table of Contents

Page Number

Pumps

ecocirc® 20 -18 ecocirc+ 20 -18 Circulators	4-7
ecocirc XL Series Heating/Cooling Circulators	8-10
ecocirc e ³ Series Potable Water Pumps	11
ecocirc wireless Potable Water Kit	12
autocirc Series Potable Water Pumps	13
ecocirc B 23-5 Portable Hot Water Recirculation Pump	14
ecocirc SC Solar Pump	14-15
NRF (Cast Iron, Maintenance-Free Wet Rotor)	16-17
NBF (Bronze, Maintenance-Free Wet Rotor)	18-19
SSF (Stainless Steel, Maintenance-Free Wet Rotor)	18-19
Series LR™ (Compact Maintenance-Free)	19
Series PL™ (Maintenance-Free Dry Motor)	20
Three Piece - Oil Lubricated Series 100, HV, PR, 2", 2-1/2" LD-3, HD-3, PD-35, PD-37, PD-38, PD-40	21
Series 60 (In-Line Mounted)	22-23

Pump Accessories

Check-Trol™ Isolation Flow Control Flange	24
Isolation and Companion Flanges	25

Controls

ecocirc Series Timer	26
NBF Aquastats and Timer	26

Relays

AZ-1A Snap-On Pump Control	27
Comfort-Trol™ Zone Control Valve	28

Valves

Temp Setter™ Thermostatic Valves	29
Circuit Setter® Plus	30
Circuit Sentry™ Flo-Setter™ II	31
Flow Control Valves Flo-Control™	32
Flow Control Valves Hydrotrol™	33
Differential Bypass Valves	33
Pressure Reducing Valves	34
ASME Safety Relief Valves	34
Monoflo® Fittings	35

Air Separators

IAS (Inline Air Separators)	35
EAS (Enhanced Air Separator)	36
EASB-JR (Enhanced Air Separator)	36

Hydronic Specialties

Air Vents	37
Vacuum Breaker	37
Drain-O-Tank® Air Charger	37
Thermoflo® Balancer	37
Primary/Secondary Header	38

Tanks

HFT Pre-Charged Hydronic Heating Tanks	39
Plain Steel Compression Tanks	39
ATF (Airtrol® Tank Fittings)	39
PTA Diaphragm Tanks	40
WTA Tanks	40
Tank Purge Valves	41

Heat Exchangers

Brazed Plate Heat Exchangers	42-43
------------------------------------	-------

CIRCULATORS ecocirc® 20-18 | ecocirc+ 20-18

High Efficiency Wet Rotor Circulator with Electronically Commutated Motor (ECM)

Description

The ecocirc 20-18 circulators are designed with a highly efficient electronically commutated permanent magnet motor (ECM Technology). Cast iron flanged models are designed for closed loop hydronic heating and cooling systems, and stainless steel flanged and union body pumps for plumbing systems or open loop heating and cooling systems.

Materials of Construction

- Pump Body: Cast Iron and Stainless Steel
- Impeller: Impact Modified PPE
- Shaft: Ceramic/Alumina
- Rotor Can: 316 Stainless Steel
- Bearings: Ceramic/Alumina
- O-Ring: EPDM
- All Other Wetted Parts: 304 or 316 Stainless Steel
- Motor Type: Electronically Commutated Permanent Magnet Motor
- Insulation Class: F
- Check Valve: 1" Noryl Check Valve shipped loose for field installation

Operating Data

- Maximum Working Pressure: 145 psi (10 Bar)
- Maximum Working Temperature: 230°F (110°C)
- Minimum Working Temperature: 14°F (-10°C)
- Ambient Temperature Range: 32°F (0°C - 10°C)

ecocirc 20-18 Features

- Maximum of 20 feet of head or 18 GPM
- 70W maximum power
- 3 modes – proportional pressure, constant pressure, or adjustable speed control
- Fluid temperature: 14-230°F
- **CircGuard™** – complete integrated system protection
- Automatic air purge to remove any air trapped in the pump
- One turn knob and multicolor LED display for easy reading and setting of the pump
- Check valve included in box
- Insulation shell included



ecocirc 20-18



ecocirc+ 20-18

Safety Standards and Protection

- Enclosure: Class 1, IP44 (equivalent to NEMA Type 2)
- UL Listed to UL 778, UL 1004-1, 1004-7, and UL 60730-1
- cUL Listed to C22.2 #108
- Electronically Thermally Protected (Integrated Motor Protection)
- Motor Insulation Class: F
- Stainless steel models are NSF/ANSI-61 certified

ecocirc+ 20-18 Features

The ecocirc+ 20-18 comes with all of the standard features found on the ecocirc 20-18 plus the following premium features:

- Bluetooth communication+
- 0-10V input+
- Temperature control+
- eAdapt autolearn and Night Mode+
- Digital display+



SCHEDULE ecocirc 20-18

CAST IRON BODY (Flanged)		STAINLESS STEEL BODY (Flanged and Union)		RATED MOTOR CHARACTERISTICS				
MODEL NUMBER	PART NUMBER	MODEL NUMBER	PART NUMBER	VOLTAGE	PHASE	Hz	WATTS RANGE	AMP RANGE
ecocirc 20-18 flanged	60B0B1000	ecocirc 20-18 stainless steel flanged	60B0B1001	115V	1	50/60	0-70	.06-1.02
		ecocirc 20-18 stainless steel union	60B0B1002	115V	1	50/60	0-70	.06-1.02

Note: Where potable water is pumped, use a stainless steel circulator. ecocirc 20-18 and ecocirc+ 20-18 circulators are recommended for indoor use only.

SCHEDULE ecocirc+ 20-18

CAST IRON BODY (Flanged)		STAINLESS STEEL BODY (Flanged and Union)		RATED MOTOR CHARACTERISTICS				
MODEL NUMBER	PART NUMBER	MODEL NUMBER	PART NUMBER	VOLTAGE	PHASE	Hz	WATTS RANGE	AMP RANGE
ecocirc+ 20-18 flanged	60B0B1003	ecocirc+ 20-18 stainless steel flanged	60B0B1004	115V	1	50/60	0-70	.06-1.02
		ecocirc+ 20-18 stainless steel union	60B0B1005	115V	1	50/60	0-70	.06-1.02

Note: Where potable water is pumped, use a stainless steel circulator. ecocirc 20-18 and ecocirc+ 20-18 circulators are recommended for indoor use only.

CIRCULATORS ecocirc® 20-18 | ecocirc+ 20-18

High Efficiency Wet Rotor Circulator with Electronically Commutated Motor (ECM)

ecocirc 20-18

One control knob, three control modes

The standard ecocirc 20-18 models include options for either cast iron or stainless steel pump housings. Like all ecocirc 20-18 pumps, they are easy to set up and operate with "just one turn." The interface gives you all the information you need, with a multicolor LED to indicate pump status.

Proportional pressure (A-B-C)

Recommended for thermostatic radiator valve applications.

Constant pressure (1-2-3)

Recommended for underfloor heating applications.

Automatic air purge

Facilitates quick and immediate air-venting for safe operation.

Fixed speed (I-II-III)

Recommended for boiler feed, single-pipe heating systems or systems with hydraulic separators.

ecocirc+ 20-18

Higher visibility, functionality and connectivity

Our more advanced ecocirc+ 20-18 range takes the idea of smart simplicity to a whole new level. Equipped with the same functionality as the standard ecocirc 20-18 range, these models all come with a three-digit display, communication via Bluetooth® wireless technology, for external monitoring, Night Mode and eAdapt to ensure optimal comfort at minimum cost.

Digital display

The 3-digit display alternates automatically to show power consumption, head and flow rate.

Multicolor LED

Green: Circulator is working properly
Green (blinking): Automatic air-purge is running
Yellow: Night Mode function (+)
Yellow (blinking): Stand-by
Red: Pump failure or dry run

eAdapt

Automatic set-up of circulator performance

Communication LED Green: communication via Bluetooth® wireless technology activated.

Night Mode and Communication selection button

Night Mode – to be activated with one of the other functional modes – ensures minimal power consumption at night time. Use the communication via Bluetooth® wireless technology to switch to a remote interface and set up the circulator.

Best-in-class efficiency

With its optimized hydraulic and high-efficiency variable speed ECM motor, the ecocirc keeps operational costs to a minimum. (EEI ≤ 0.18).

Easy maintenance

The motor assembly can be easily removed for maintenance via four screws.

User friendliness

The friendly design provides hassle-free set-up of the pump.

Bluetooth connectivity

(ecocirc+ 20-18 only)
 The ability to connect directly to the pump allows full control and monitoring of the pump.

Full control (ecocirc+ 20-18 only)

Wireless connectivity lets the user maximize the hydronic system, either through automated energy saving features such as eAdapt and Night Mode, or through the 0-10V input.

Insulation shell

This included component helps maintain the water temperature.

Pump protection (CircGuard™)

CircGuard provides built-in dry run protection stops the pump to avoid damage and ensure that the product lasts longer.

Blocked rotor resistance (CircGuard™)

Through its industry-leading CircGuard patented construction, including a ceramic shaft and ceramic bearings combination, the ecocirc 20-18 avoids blocked rotors better.

CIRCULATORS ecocirc® 20-18 | ecocirc+ 20-18

High Efficiency Wet Rotor Circulator with Electronically Commutated Motor (ECM)

Constant Pressure Curve

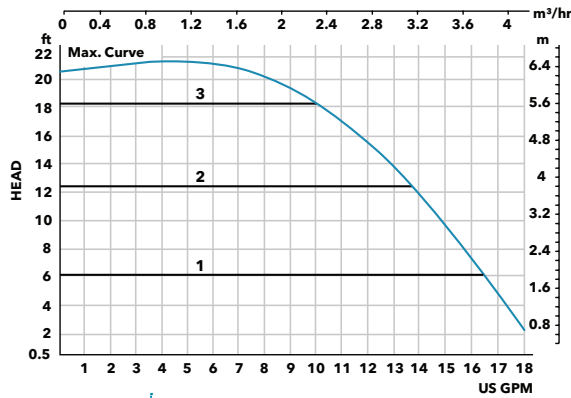

Proportional Pressure Curve

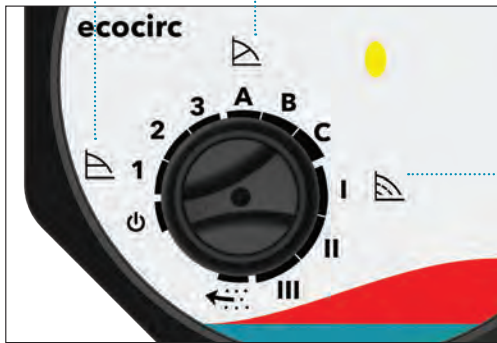
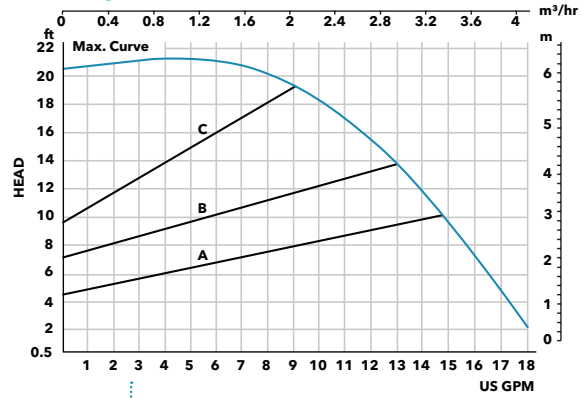

Fixed Speed Curve

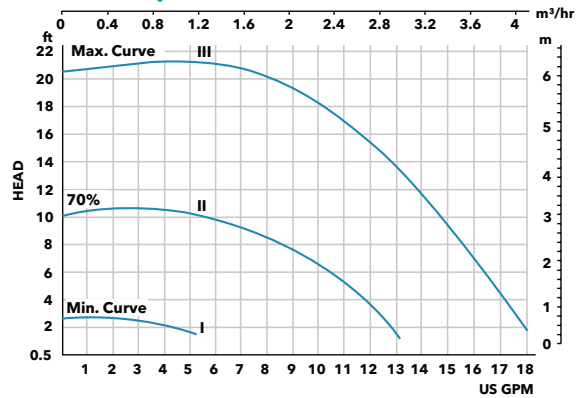

Standard Operating Modes

CONSTANT SPEED



The pump maintains a constant speed at any flow rate. The desired speed is set on the interface panel of the pump.

CONSTANT PRESSURE ($\Delta p-c$)

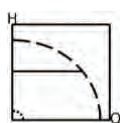

The pump maintains a constant differential pressure at any flow demand until the maximum speed is reached. The desired head of the pump can be set via user interface. Recommended for use in systems with small or constant pressure losses.

PROPORTIONAL PRESSURE ($\Delta p-v$)

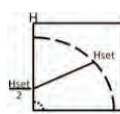

The differential pressure continuously increases or decreases based on the flow demand. The set point head can be set on the pump user interface. Use for systems with large pressure losses.

NIGHT MODE (ecocirc+ 20-18 only)

The pump will automatically reduce speed when there is an abrupt change in fluid temperature. The change in fluid temperature is from a boiler operating in night time setback mode. The external temperature sensor is used. (Fixed Speed, Constant Pressure, Proportional Pressure)

Temperature Dependent Operating Modes (ecocirc+ 20-18 only)

SET POINT TEMPERATURE ($\Delta p-T$) (ecocirc+ 20-18 only)



The nominal differential pressure set point is modified based on the fluid temperature. Uses an external temperature sensor.

SET POINT TEMPERATURE (T) (ecocirc+ 20-18 only)

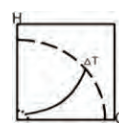

The pump maintains a constant temperature in a system, such as domestic hot water system or a single temperature heating system. Uses an external temperature sensor.

eAdapt (ecocirc+ 20-18 only)

The pump will optimize the energy consumption by identifying the ideal duty point.

Air Purge

Air purge will remove the dissolved gases from the pump.

INPUT SIGNALS (ecocirc+ 20-18 only)

One 0-10V (Analog): Speed Control by external controller
One external temperature sensor input for temperature modes.
Sensor Type: KYT38, P/N: 104502

CIRCULATORS ecocirc® 20-18 | ecocirc+ 20-18

High Efficiency Wet Rotor Circulator with Electronically Commutated Motor (ECM)

ecocirc/ecocirc+ 20-18 PUMP DIMENSIONS (FLANGED)

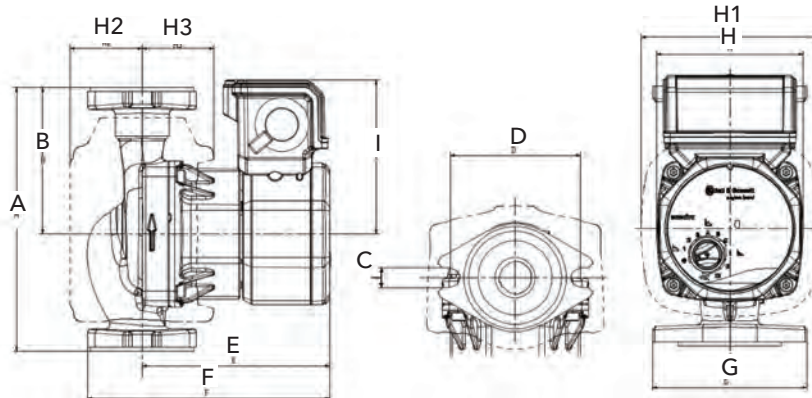

MODEL NUMBER	DIMENSIONS - INCHES (mm)									APPROX. SHIPPING WEIGHT LB. (KG)	
	A	B	E	F	H	H1	H2	H3	I	CAST IRON	STAINLESS STEEL
ecocirc 20-18 flanged	6.38" (162)	3.54" (90)	4.57" (116)	5.9" (150)	3.54" (90)	4.29" (109)	1.73" (44)	1.73" (44)	3.74" (95)	6.2 lb. (2.81)	5.86 lb. (2.66)
ecocirc+ 20-18 flanged	6.38" (162)	3.54" (90)	4.57" (116)	5.9" (150)	3.54" (90)	4.29" (109)	1.73" (44)	1.73" (44)	3.74" (95)	6.2 lb. (2.81)	5.86 lb. (2.66)

MODEL NUMBER	FLANGED SIZE INCHES - NPT	# OF BOLTS	DIMENSIONS - INCHES (mm)			COMPANION FLANGE PART NUMBERS	
			C	D	G	CAST IRON PN	STAINLESS STEEL PN
ecocirc 20-18 flanged	¾", 1", 1-¼", 1-½"	2	.47" (12)	3.15" (80)	3.74" (95)	101201-101204	101501LF - 101504LF
ecocirc+ 20-18 flanged	¾", 1", 1-¼", 1-½"	2	.47" (12)	3.15" (80)	3.74" (95)	101201-101204	101501LF - 101504LF

ecocirc/ecocirc+ 20-18 PUMP DIMENSIONS (UNION)

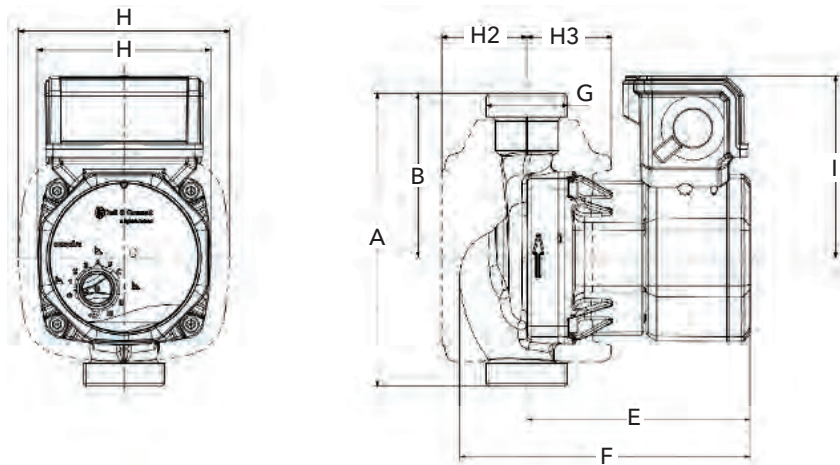

MODEL NUMBER	DIMENSIONS - INCHES (mm)									APPROX. SHIPPING WEIGHT LB. (KG)	
	A	B	E	F	H	H1	H2	H3	I	CAST IRON	STAINLESS STEEL
ecocirc 20-18 union	6" (152.4)	3.36" (85.4)	4.57" (116)	5.9" (150)	3.54" (90)	4.29" (109)	1.73" (44)	1.73" (44)	3.74" (95)	N/A	4.61 lb. (2.09)
ecocirc+ 20-18 union	6" (152)	3.36" (85.4)	4.57" (116)	5.9" (150)	3.54" (90)	4.29" (109)	1.73" (44)	1.73" (44)	3.74" (95)	N/A	4.61 lb. (2.09)

MODEL NUMBER	UNION TAILPIECE SIZE INCHES - NPT	# OF BOLTS	DIMENSIONS - INCHES (mm)		UNION CONNECTOR KIT PART NUMBERS
			G	CAST IRON PN	BRONZE PN
ecocirc 20-18 union	½" Sweat, ¾" Sweat, ¾" NPT	0	1 ¼" NPSM	N/A	113203LF, 113201LF, 113202LF
ecocirc+ 20-18 union	½" Sweat, ¾" Sweat, ¾" NPT	0	1 ¼" NPSM	N/A	113203LF, 113201LF, 113202LF

CIRCULATORS ecocirc® XL

High efficiency large wet rotor pump for heating, cooling and potable water systems. Available in single and three phase power options.

Description

The ecocirc XL is a high efficiency, variable speed, wet rotor pump with integrated drive. The circulator is available in cast iron or stainless steel and has a broad operating temperature range of 14°F to 230°F (-10°C to 110°C). The ecocirc XL is suitable for both hot and chilled water systems.

The ecocirc XL circulator is designed with a highly efficient electronically commutated permanent magnet motor (ECM/PM Technology). This circulator can enhance hydronics systems with superior quality and dependability. State-of-the-art hydraulics, advanced motor design, intelligent controls, and smart communication capabilities highlight expert engineering across a board range of HVAC and plumbing applications.

Materials of Construction

- Pump Body: Cast Iron or Stainless Steel
- Impeller 1/12-1/16 hp: Polyphenylene Sulfide 1/2 hp+: Stainless Steel
- Shaft: AISI 420 Stainless Steel
- Rotor: Permanent Magnet
- Bearing: Carbon Sleeve
- Gasket/O-Ring: EPDM
- All Other Wetted Parts: AISI 304 Stainless Steel
- Motor Type: Electronically Commutated Motor /Permanent Magnet
- Motor Insulation Class: F

Operating Data

- Maximum Working Pressure: 175 PSI (12 Bar)
- Minimum Working Temperature: 14°F (-10°C)
- Maximum Working Temperature: 230°F (110°C)
- Ambient Temperature Range: 32°F - 104°F (0°C - 40°C)

Safety Standards And Protection

- Enclosure: Class 2, IP44 (equivalent to NEMA Type 2)
- UL Listed to UL 778; UL 1004-1, 1004-7; and UL 60730-1
- cUL Listed to C22.2 #108
- Electronically Thermally Protected (Integrated Motor Protection)
- Motor Insulation Class: F
- CSA Certified to ANSI/NSF 61 that product contains less than 0.25% lead content by weight on wetted surface



ecocirc XL High Head Performance Range

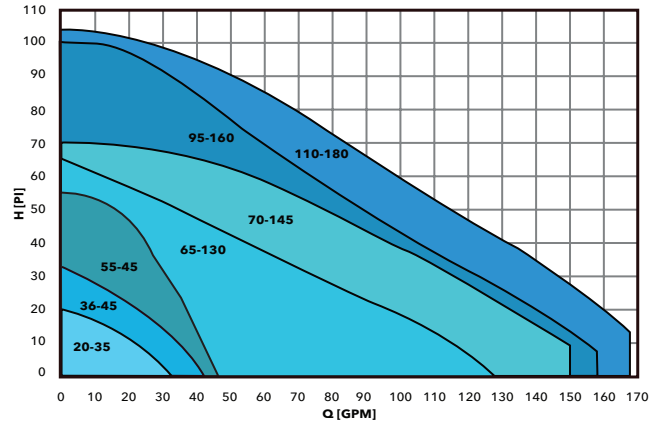

ecocirc XL High Flow Performance Range

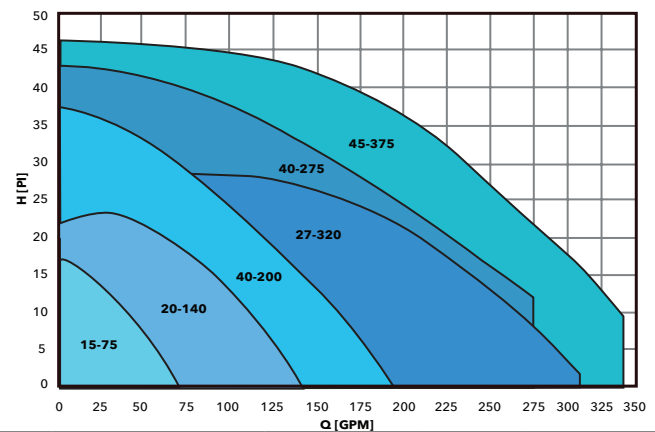

Cast Iron Body		Stainless Steel Body*		Rated Motor Characteristics					
Model Number	Part Number	Model Number	Part Number	HP**	Voltage	Phase	Hz	Watts	AMP Range
ecocirc XL 20-35	104300	ecocirc XL N 20-35	104450LF	1/12	115	1	50/60	6-85	0.1 - 1.3
ecocirc XL 36-45	104301	ecocirc XL N 36-45	104451LF	1/6	115	1	50/60	20-200	0.1 - 3.0
ecocirc XL 36-45	104302	ecocirc XL N 36-45	104452LF	1/6	208-230	1	50/60	20-150	0.1 - 1.5
ecocirc XL 15-75	104303	ecocirc XL N 15-75	104453LF	1/6	115	1	50/60	30-150	0.1 - 2.3
ecocirc XL 15-75	104304	ecocirc XL N 15-75	104454LF	1/6	208-230	1	50/60	30-150	0.1 - 1.1
ecocirc XL 55-45	104306	ecocirc XL N 55-45	104456LF	1/2	208-230	1	50/60	30-500	0.2 - 2.0
ecocirc XL 20-140	104308	ecocirc XL N 20-140	104458LF	1/2	208-230	1	50/60	35-470	0.2 - 2.0
ecocirc XL 65-130	104309	ecocirc XL N 65-130	104459LF	1	208-230	1	50/60	45-825	0.5 - 3.5
ecocirc XL 40-200	104312	ecocirc XL N 40-200	104462LF	1	208-230	1	50/60	45-825	0.5 - 3.5
ecocirc XL 70-145	104315	ecocirc XL N 70-145	104465LF	2	208-230	1	50/60	55-1400	0.6 - 6.0
ecocirc XL 40-275	104318	ecocirc XL N 40-275	104468LF	2	208-230	1	50/60	50-1400	0.5 - 6.0
ecocirc XL 65-130	104310	ecocirc XL N 65-130	104460LF	1	208-230/400-460	3	50/60	50-800	0.5 - 2.8/2.0
ecocirc XL 40-200	104313	ecocirc XL N 40-200	104463LF	1	208-230/400-460	3	50/60	50-800	0.5 - 2.8/2.0
ecocirc XL 95-160	104321	ecocirc XL N 95-160	104471LF	2	208-230/400-460	3	50/60	50-1250	0.5 - 4.4/2.0
ecocirc XL 27-320	104323	ecocirc XL N 27-320	104473LF	2	208-230/400-460	3	50/60	50-1500	0.5 - 4.4/3.0
ecocirc XL 110-180	104326	ecocirc XL N 110-180	104476LF	3	400-460	3	50/60	50-2000	0.5 - 3.7
ecocirc XL 45-375	104328	ecocirc XL N 45-375	104478LF	3	400-460	3	50/60	50-2150	0.5 - 4.0

Note: Where potable water is pumped, use a stainless steel. ecocirc XL pumps are recommended for indoor use only.

*CSA Certified to ANSI/NSF 61 that product contains less than 0.25% lead content by weight on wetted surface.

** Nominal HP

CIRCULATORS ecocirc® XL

High efficiency large wet rotor pump for heating, cooling and potable water systems

User-friendly interface

With only four logically placed buttons on an intuitive interface, it's easy to set and operate the new ecocirc XL. Advanced settings enable custom programming, accessible via a PC, smartphone or wireless enabled device.

Economical operation

A highly efficient ECM motor combined with optimized pump hydraulics, keeps operational costs at a minimum.

Chilled water applications

Electronics are separated from the pump to prevent condensation for worry free operation even at 14°F (-10°C).

High visibility

Even in dark mechanical rooms, a bright display with large figures and symbols makes it easy to view pump status.

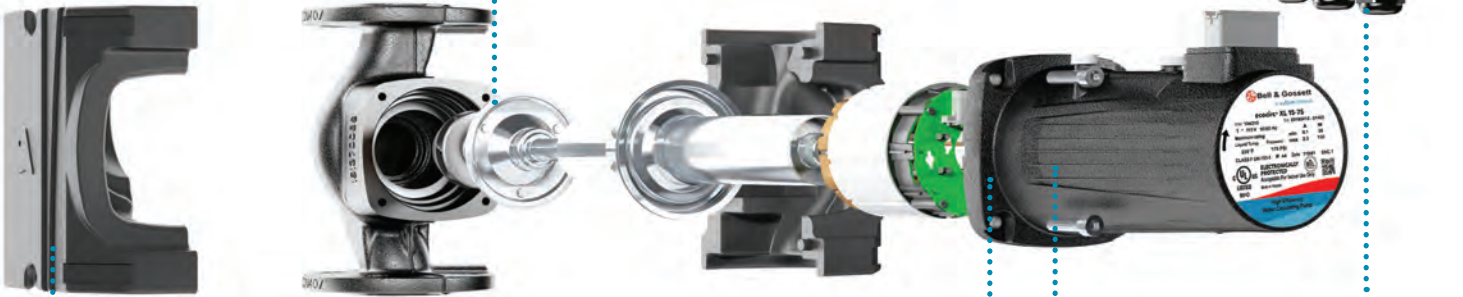
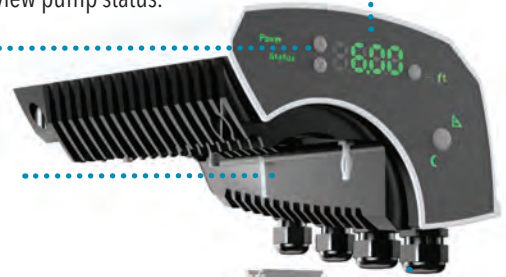

Keep it insulated

A perfectly molded insulation shell helps in preserving the constant temperature of the pumped heating medium.

Pump protection

Built-in dry-run protection stops pump operation in the absence of water, preventing damage and costly repairs.

Chilled water applications

Electronics are separated from the pump to prevent condensation for worry free operation even at 14°F (-10°C).

Increase your control options

Multiple inputs including start-stop, temperature control, pressure regulation and advanced Modbus or BACnet control provide dynamic system management.

Product Range Chart

Model Number	Version		Power Supply				Flange Connection				Pump Body			Fluid Temp. Range	Ambient Temp. Range	Maximum Pressure Range	Protection Class
	High Head	High Flow	Single Phase 115V	Single Phase 208-230V	3 Phase 208-230/400-460V	3 Phase 400-460V	Small Booster (2 Bolts)	Large Booster (2 Bolts)	2" Booster (4 Bolts)	3" Booster (4 Bolts)	Cast Iron	Stainless Steel	Impeller Type	14°F - 230°F	32°F - 104°F	175 PSI	IP44
ecocirc XL 20-35	•		•				•				•	•	P	•	•	•	•
ecocirc XL 36-45	•		•	•			•				•	•	P	•	•	•	•
ecocirc XL 15-75		•	•	•					•		•	•	P	•	•	•	•
ecocirc XL 55-45	•			•			•				•	•	S	•	•	•	•
ecocirc XL 20-140		•		•					•		•	•	S	•	•	•	•
ecocirc XL 65-130	•			•	•			•			•	•	S	•	•	•	•
ecocirc XL 40-200		•		•	•				•		•	•	S	•	•	•	•
ecocirc XL 70-145	•			•				•			•	•	S	•	•	•	•
ecocirc XL 40-275		•		•					•		•	•	S	•	•	•	•
ecocirc XL 95-160	•				•			•			•	•	S	•	•	•	•
ecocirc XL 27-320		•			•				•		•	•	S	•	•	•	•
ecocirc XL 110-180	•					•		•			•	•	S	•	•	•	•
ecocirc XL 45-375		•				•			•		•	•	S	•	•	•	•

*CSA Certified to ANSI/NSF 61 that product contains less than 0.25% lead content by weight on wetted surface.

** P-Polyphenylene Sulfide; S-Stainless Steel

- Small Booster (2 bolts) has a bolt hole to bolt hole dimension of 3-3/16".
- Large Booster (2 bolts) has a bolt hole to bolt hole dimension of 3-7/16".



Input Signals

- One 0-10V (Analog): Speed Control by external controller
- One 4-20mA (Analog): Connection with an external differential pressure sensor for the pressure control mode (two different pressure sensor range: 0-15 PSI PN: 104503 and 0-30 PSI PN: 104504)
- One external temperature sensor input for either Constant Temperature or Temperature Influenced modes. Sensor PN: 104502
- One built-in temperature sensor for either Constant Temperature or Temperature Influenced modes.

Remote Building Management System Capabilities

- The pump can be monitored or controlled by a signal from a BMS (Building Management System). Built-in protocols are BACnet BLT and Modbus. Direct connection to a PC is available.
- An optional wireless module can be added to create a short range wireless field for remote connection to the pump. An internet browser or an App can be used to program the advanced settings. Module PN: 104500

CIRCULATORS ecocirc® XL

High efficiency large wet rotor pump for heating, cooling and potable water systems

STANDARD OPERATING MODES

Constant Speed



The pump maintains a constant speed at any flow rate. The desired speed is set on the interface panel of the pump.

Constant Pressure ($\Delta p-c$)



The pump maintains a constant differential pressure at any flow demand until the maximum speed is reached. The desired head of the pump can be set via user interface.

Proportional Pressure ($\Delta p-v$)



The differential pressure continuously increases or decreases based on the flow demand. The set point head can be set on the pump user interface.

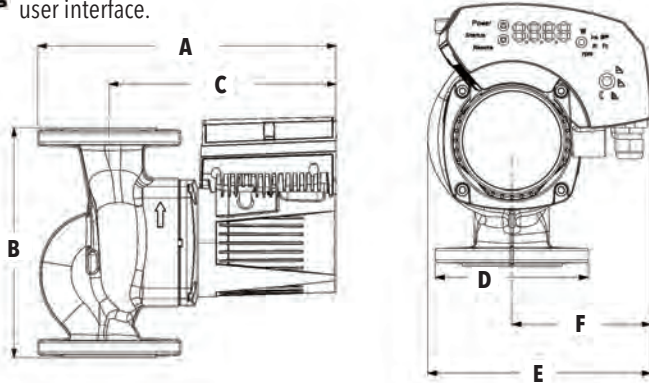

Night Mode



The pump will automatically reduce speed when there is an abrupt change in fluid temperature. The change in fluid temperature is from a boiler operating in night time setback mode. The built-in temperature sensor is used.

CONSTANT TEMPERATURE SPEED CONTROL

T- Constant Control

This control mode will use a PI algorithm to vary the speed of the pump in order to maintain a constant temperature of the fluid media.

ΔT -Constant Control

This control mode will use a PI algorithm to vary the speed of the pump in order to maintain a constant differential temperature between the built-in temperature sensor and external temperature sensor.

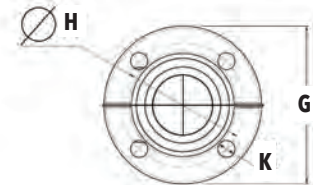
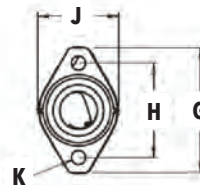

Model Number	Nominal Motor HP	Dimensions - Inches (mm)						Approx. Shipping Weight Lbs. (Kg)	
		A	B	C	D	E	F	Cast Iron	Bronze
ecocirc XL 20-35	1/12	9.94 (252)	6.38 (162)	8.20 (208)	4.19 (106)	7.20 (183)	4.72 (120)	19.8 (9)	22 (10)
ecocirc XL 36-45	1/6	9.94 (252)	6.38 (162)	8.20 (208)	4.19 (106)	7.20 (183)	4.72 (120)	19.8 (9)	22 (10)
ecocirc XL 15-75	1/6	11.04 (280)	8.5 (216)	8.39 (213)	5.19 (132)	7.57 (192)	4.72 (120)	26.4 (12)	28.6 (13)
ecocirc XL 55-45	1/2	11.89 (302)	6.38 (162)	10.18 (258)	4.19 (106)	8.12 (206)	5.02 (127)	26.4 (12)	28.6 (13)
ecocirc XL 20-140	1/2	13.39 (340)	11.5 (292)	10.41 (264)	5.19 (132)	8.20 (208)	5.02 (127)	35.2 (16)	39.6 (18)
ecocirc XL 65-130	1	14.84 (377)	11.5 (292)	11.80 (299)	4.62 (117)	9.53 (242)	5.77 (146)	39.6 (18)	44 (20)
ecocirc XL 40-200	1	15.17 (385)	11.5 (292)	11.80 (299)	5.19 (132)	9.53 (242)	5.77 (146)	41.8 (19)	46.2 (21)
ecocirc XL 70-145	2	14.84 (377)	11.5 (292)	11.80 (299)	4.62 (117)	9.53 (242)	5.77 (146)	38.4 (17)	44 (20)
ecocirc XL 40-275	2	16.04 (407)	12.0 (305)	12.57 (319)	6.00 (152)	10.07 (256)	5.77 (146)	49.6 (23)	55 (25)
ecocirc XL 65-130	1	14.96 (380)	11.5 (292)	11.85 (301)	2.87 (73)	10.43 (265)	5.31 (135)	39.6 (18)	44 (20)
ecocirc XL 40-200	1	15.23 (387)	11.5 (292)	11.85 (301)	5.19 (132)	10.43 (265)	5.31 (135)	35.2 (16)	39.6 (18)
ecocirc XL 95-160	2	14.44 (367)	11.5 (292)	11.37 (289)	2.87 (73)	10.43 (265)	5.31 (135)	39.6 (18)	44 (20)
ecocirc XL 27-320	2	15.27 (388)	14.17 (360)	11.81 (300)	6.00 (152)	10.43 (265)	5.31 (135)	49.6 (23)	55 (25)
ecocirc XL 110-180	3	14.44 (367)	11.5 (292)	11.37 (289)	2.87 (73)	10.43 (265)	5.31 (135)	38.4 (17)	44 (20)
ecocirc XL 45-375	3	16.14 (410)	14.17 (360)	12.67 (321)	6.00 (152)	10.43 (265)	5.31 (135)	49.6 (23)	55 (25)

Model Number	Flange Size Inches - NPT	# of Bolts	Dimensions - Inches (mm)				B&G Companion Flange (Set of 2)	
			G	H	J	K	Cast Iron PN	Bronze PN
ecocirc XL 20-35	3/4, 1, 1-1/4, 1-1/2	2	4.19 (106)	3.16 (80)	2.62 (66)	0.47 (12)	101201 - 101204*	101208LF - 101211LF*
ecocirc XL 36-45	3/4, 1, 1-1/4, 1-1/2	2	4.19 (106)	3.16 (80)	2.62 (66)	0.47 (12)	101201 - 101204*	101208LF - 101211LF*
ecocirc XL 15-75	2	4	5.18 (132)	4.06 (103)	-	0.56 (14)	101215	101216LF
ecocirc XL 55-45	3/4, 1, 1-1/4, 1-1/2	2	4.19 (106)	3.16 (80)	2.62 (66)	0.47 (12)	101201 - 101204*	101208LF - 101211LF*
ecocirc XL 20-140	2	4	5.19 (132)	4.06 (103)	-	0.56 (14)	101215	101216LF
ecocirc XL 65-130	1, 1-1/4, 1-1/2	2	4.62 (117)	3.44 (87)	2.86 (73)	0.47 (12)	101205 - 101207*	101212LF - 101214LF*
ecocirc XL 40-200	2	4	5.19 (132)	4.06 (103)	4.06 (103)	0.56 (14)	101215	101216LF
ecocirc XL 70-145	1, 1-1/4, 1-1/2	2	4.62 (117)	3.44 (87)	2.86 (73)	0.47 (12)	101205 - 101207*	101212LF - 101214LF*
ecocirc XL 40-275	3	4	6.00 (152)	5.06 (129)	-	0.53 (13)	101217	101218LF
ecocirc XL 65-130	1, 1-1/4, 1-1/2	2	4.62 (117)	3.44 (87)	2.86 (73)	0.47 (12)	101205 - 101207	101212LF - 101214LF
ecocirc XL 40-200	2	4	5.19 (132)	4.06 (103)	-	0.56 (14)	101215	101216LF
ecocirc XL 95-160	1, 1-1/4, 1-1/2	2	4.62 (117)	3.44 (87)	2.86 (73)	0.47 (12)	101205 - 101207	101212LF - 101214LF
ecocirc XL 27-320	3	4	6.00 (152)	5.06 (129)	-	0.53 (13)	101217	101218LF
ecocirc XL 110-180	1, 1-1/4, 1-1/2	2	4.62 (117)	3.44 (87)	2.86 (73)	0.47 (12)	101205 - 101207	101212LF - 101214LF
ecocirc XL 45-375	3	4	6.00 (152)	5.06 (129)	-	0.53 (13)	101217	101218LF

* Part numbers represent a Master Carton of 12 flanges with fasteners pack.
1-1/2" is the diameter of the suction and discharge for the 2-bolt models.

CIRCULATORS ecocirc® Series

Potable Hot Water Recirculation Pumps - Whole House

Description

e³ circulators are energy efficient circulators using permanent magnet, ECM (electronically commutated motor) technology. The e³ circulators are designed specifically for potable water applications. These circulators are lead-free* and come with a variety of options including a temperature sensor, various body styles, assembled with electrical cord and plug. Timer sold as an accessory (See page 24 for more information).

Materials of Construction

Pump Body: Lead-Free* Brass
 O-Ring: EPDM or Viton
 Bearing: Carbon/Alumina Ceramic
 Impeller: Nylon/PPO
 Motor: High Efficiency ECM
 All Other Wetted Parts: Type 316 Stainless Steel,
 Shaft-less and seal-less construction

Operating Data Pump

Maximum Working Pressure: 150 PSI (10.3 Bar)
 Maximum Working Temperature: 203°F (95°C)
 Minimum Working Temperature: 50°F (10°C)

Motor

ECM Spherical Motor
 10-28 Watts Power Consumption
 Automatic Overload Protection
 Low in-rush current

Adjustable Speed Switch (Models Without Temp Sensor)

Infinitely variable-speed switch to manually adjust motor speed.

Adjustable Temperature Sensor (Fixed Speed Only)

Adjustable Set Point from 68°F to 158°F (20°C to 70°C)
 Turns circulator OFF when water temperature reaches set point
 Turns circulator ON when water temperature is 10°F (6°C) below set point

Connections

1/2" UltraCirc with Ball & Check Valve
 1/2" Sweat
 1/2" FNPT Threaded



e³ Timer
(See Page 26)

e³ - 4, e³ - 6

Pump Curves

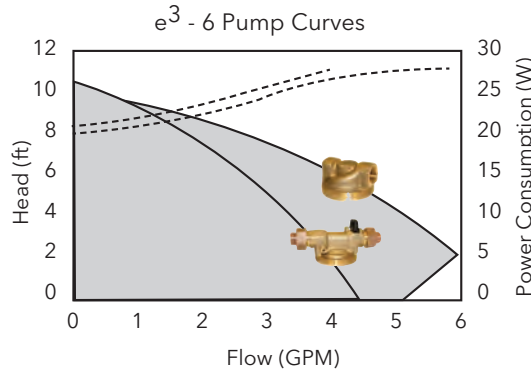
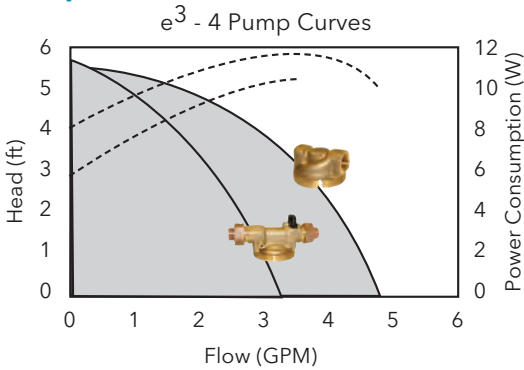

— UltraCirc Housing Flow - - - - UltraCirc Housing Energy Consumption
 — NPT/Sweat Housing Flow - - - - NPT/Sweat Housing Energy Consumption

UltraCirc Pump Housing (Union with Ball & Check Valve)

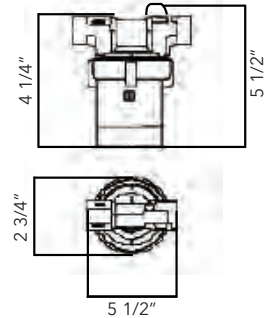

Standard Pump Housing (Sweat & Threaded)

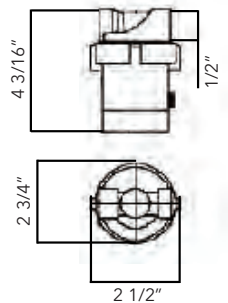

Model Number	Part Number	Materials	Connection		Adjustable Speed	Adjustable Thermostat	Plug
			Size	Type			
e ³ -4V/BSPYZ	60A0B1001	Lead-Free Brass	1/2"	Sweat	•		•
e ³ -4F/BSXRZ	60A0B3001	Lead-Free Brass	1/2"	Sweat		•	
e ³ -4V/BTXYZ	60A0B1002	Lead-Free Brass	1/2"	FNPT	•		
e ³ -4F/BTPRZ	60A0B3002	Lead-Free Brass	1/2"	FNPT		•	•
e ³ -6V/BSPYZ	60A0B1004	Lead-Free Brass	1/2"	Sweat	•		•
e ³ -6V/BTXYZ	60A0B1006	Lead-Free Brass	1/2"	FNPT	•		
e ³ -6V/BTPYZ	60A0B1005	Lead-Free Brass	1/2"	FNPT	•		•
e ³ -4V/BUPYZ	60A0B1003	Lead-Free Brass	1/2"	Union	•		•
e ³ -4F/BUPRZ	60A0B3003	Lead-Free Brass	1/2"	Union		•	•
e ³ -6V/BUPYZ	60A0B1007	Lead-Free Brass	1/2"	Union	•		•
e ³ -6F/BSPRZ	60A0B3004	Lead-Free Brass	1/2"	Union		•	•
e ³ .TIMER	60AABT001	-	-	-			

*CSA certified to NSF/ANSI 372 that product contains less than 0.25% lead content by weight on wetted surface.

CIRCULATORS ecocirc® wireless

Potable Hot Water Recirculation Kit

Description

The ecocirc wireless is a potable hot water recirculation kit (a pump and valve combination) for instant supply of hot water supply throughout the entire house.

The ecocirc pump is installed on the supply side of the hot water source and the mixing valve under the sink farthest away from the hot water source. The pump and valve are in constant wireless communication.

How it Works

The desired water temperature at the valve is set directly on the pump with the thermostat dial. The water temperature is constantly checked by the valve and the temperature values are sent to the pump. At approximately 5°F below the desired water temperature, the pump will begin to circulate hot water. This circulation will open the valve for hot water to cross into the cold water line, which creates a return loop back to the hot water source. When the desired temperature is reached, the pump will stop circulating. This is to prevent continuous circulation.

An Optional Push Button / Signal Repeater

A wireless device to provide instant hot water with a push of a button. The push button device will override the timer operation and activate the pump to circulate hot water until the desired temperature is met at the valve. This device also functions as a signal repeater when the pump and valve have a weak signal due to distance or interference.



Operating Data

Maximum Operating Temperature: 203°F (95°C)
 Maximum Operating Pressure: 145 PSI (10 Bar)
 Power Supply: 115 Volts, 60 HZ, 1 Phase
 Power Consumption: 20 Watts
 Operating Noise Level: 30 dB
 Batteries: 2 AA Alkaline
 Estimated Battery Life: 2 Years
 Maximum Transmitter Range: 150 ft

Materials of Construction

Circulator Pump	Paired Mixing Valve
Body: Lead-Free* Brass	Body: Lead-Free* Brass
Seals: EPDM	Springs: Stainless Steel
Impeller: Nylon/PPO	Valve Insert: Acetal Plastic
Internals: 316 Stainless Steel	Seals: EPDM
	Transmitter Housing: ABS Plastic

*CSA certified to NSF/ANSI 372 that product contains less than 0.25% lead content by weight on wetted surface.

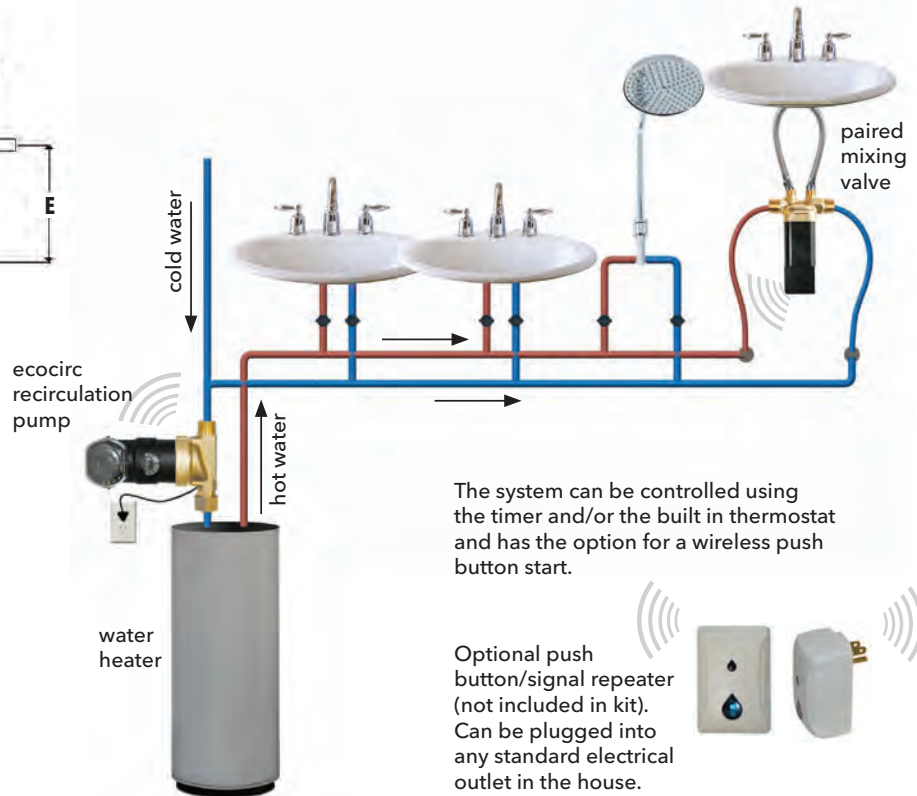
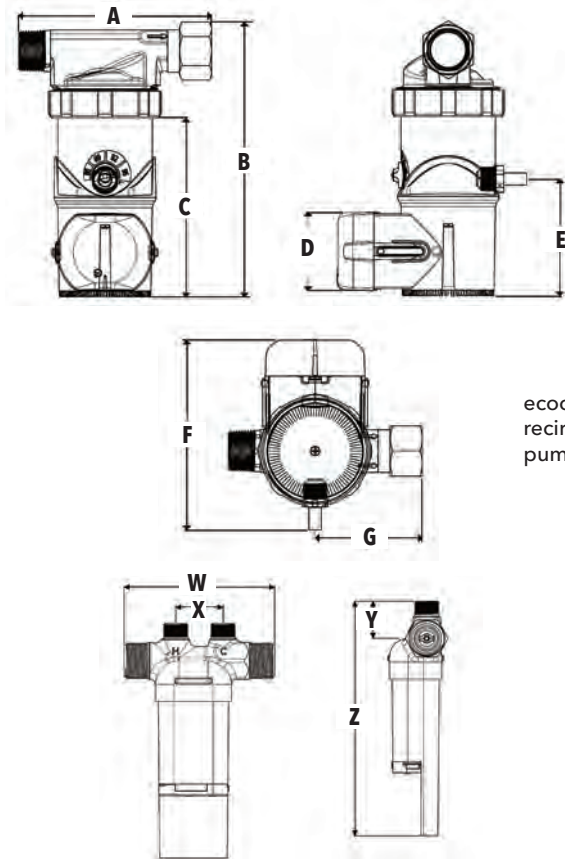

The system can be controlled using the timer and/or the built in thermostat and has the option for a wireless push button start.

Optional push button/signal repeater (not included in kit). Can be plugged into any standard electrical outlet in the house.



Model Number	Part Number	Connection	Dimension Inches (mm)											Shipping WT. LBS. (kg)
			A	B	C	D	E	F	G	W	X	Y	Z	
ecocirc wireless Recirculation Kit	6050B4000	Pump: 3/4" M/F NPT Valve: 1/2" MNPT x 3/8" compression	4.84 (123)	6.87 (174.6)	4.47 (113.5)	1.97 (50.1)	2.93 (74.4)	4.74 (120.5)	2.68 (68)	3.5 (89)	1.1 (28)	0.87 (22)	5.45 (138.5)	3.9 (1.8)
Push Button/Signal Repeater	6099B1500													

CIRCULATORS autocirc® Series

Potable Hot Water Recirculation Pumps - Undersink

Description

autocirc® circulators are energy efficient using permanent magnet, ECM (electronically commutated motor) technology. The autocirc circulators are designed specifically for standard water heaters. These circulators are lead-free* and are assembled with a timer, cord and plug.

Materials of Construction

Pump Body: Lead-Free* Brass
 O-Ring: EPDM
 Bearing: Carbon/Ceramic
 Impeller: Nylon/PPO
 Motor: High Efficiency ECM
 All Other Wetted Parts: Type 316 Stainless Steel,
 Shaft-less and Seal-less construction.

Operating Data Pump

Maximum Working Pressure: 145 PSI (10 Bar)
 Maximum Working Temperature: 203°F (95°C)
 Minimum Working Temperature: 50°F (10°C)

Motor

ECM Spherical Motor
 115 Volt 60 Hz, 1 Phase
 14 Watts Power Consumption
 Automatic Overload Protection
 Low in-rush current



e³-4_-/BDPQC

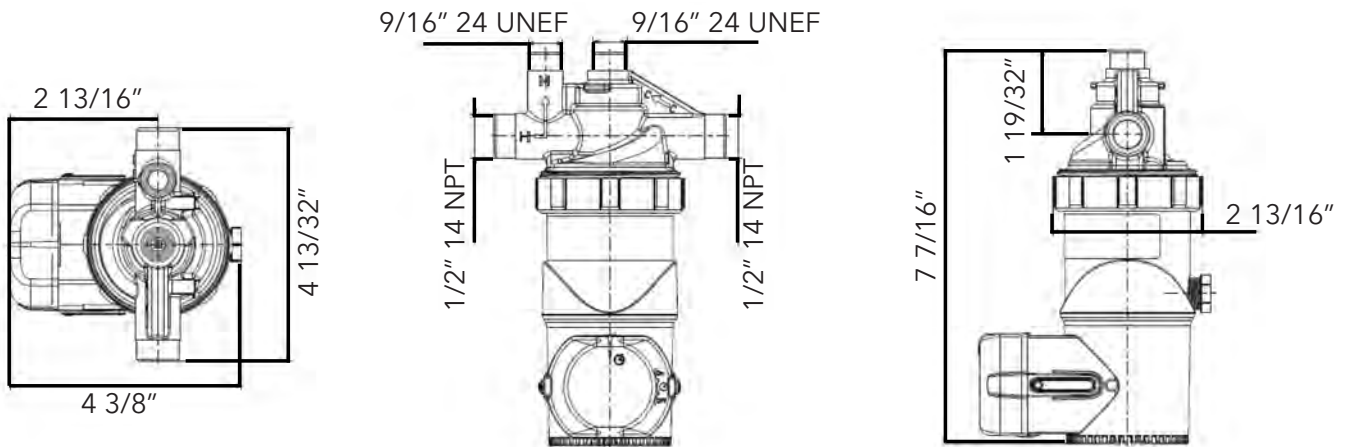
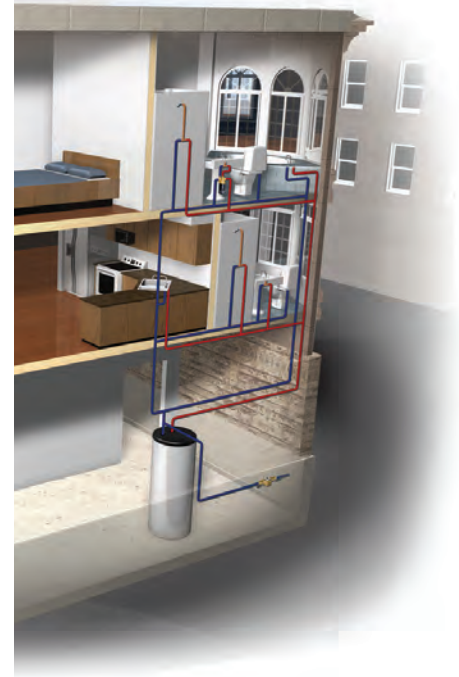

Model Number	Part Number	Description	Weight
e ³ -4F/BAPQC	60A0B6001	Lead-Free Brass autocirc 1/2" Fixed Thermostat with Timer	4 lbs.
e ³ -4F/BAPRC	60A0B6002	Lead-Free Brass autocirc 1/2" Adjustable "ON" Thermostat with Timer	4 lbs.

*CSA certified to NSF/ANSI 372 that product contains less than 0.25% lead content by weight on wetted surface.

CIRCULATORS ecocirc® B 23-5 ACT

Potable Hot Water Recirculation Pumps - Undersink

Description

The ecocirc B 23-5 ACT lead-free* pump was designed with highly efficient electronically commutated permanent magnet motor (ECM/PM technology) specifically for potable water systems. This unique design is perfect for retrofits and systems with tankless water heaters. No recirculation pipe is required.

Materials of Construction

Pump Body: Lead-Free* Brass
 O-Ring: EPDM
 Bearing: Carbon/Ceramic
 Impeller: Nylon/PPO
 Motor: High Efficiency ECM
 All Other Wetted Parts: Type 316 Stainless Steel,
 Shaft-less and Seal-less construction



ecocirc B 23-5 ACT

Operating Data Pump

Maximum Working Pressure: 145 PSI (10 Bar)
 Maximum Working Temperature: 203°F (95°C)
 Minimum Working Temperature: 50°F (10°C)

Motor

ECM Spherical Motor
 115 Volt 60 Hz, 1 Phase
 60 Watts Power Consumption
 Automatic Overload Protection
 Low in-rush current

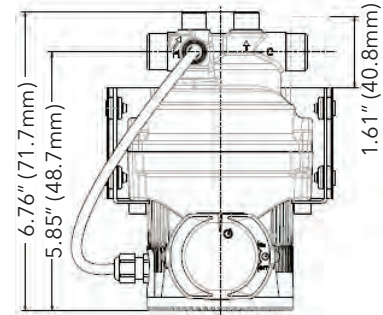
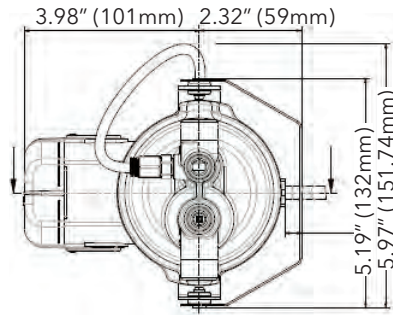

Model Number	Part Number	Description	Weight
ecocirc B 23-5 ACT	6050B7016	Lead-Free Brass autocirc 1/2" Fixed Thermostat with Timer	6.50 lbs.

*CSA certified to NSF/ANSI 372 that product contains less than 0.25% lead content by weight on wetted surface.

CIRCULATORS ecocirc® SC Solar Pump

Spherical Motor Pump

Application

- The ecocirc solar pump can be used for most circulation pump applications without connection to the power grid with direct connection to a photovoltaic panel.
- This pump is perfect for single family home thermal solar systems or any circulation pump application where conventional power is not available, on closed loop systems

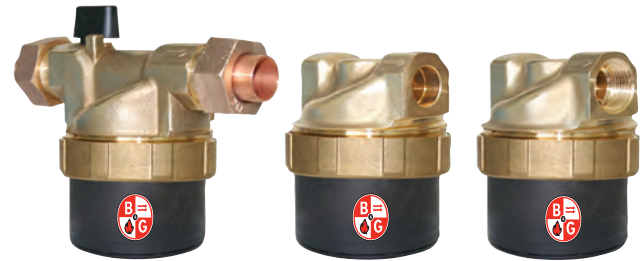

Design

- The only moving part is a hemispherical rotor/impeller unit which sits on an ultra-hard, wear-resistant ceramic ball.
- There are no conventional shaft bearings or seals eliminating bearing noise and seal leaks.
- This pump is robust and has an estimated service life in excess of 50,000 hours.
- All parts exposed to the fluid are completely corrosion resistant.

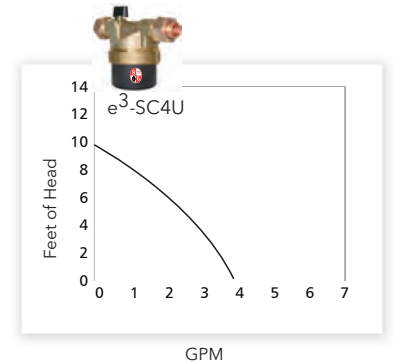
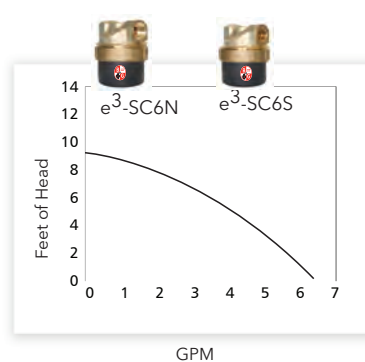

CIRCULATORS ecocirc® SC Solar Pump

Spherical Motor Pump

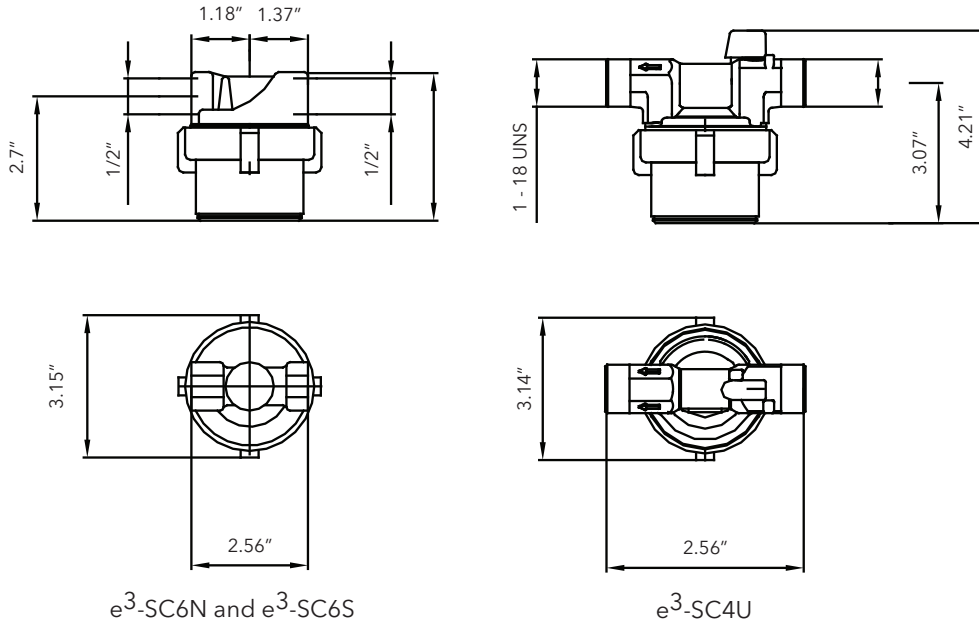

e³-SC6N and e³-SC6S

e³-SC4U

Soft Start-up

- When the photovoltaic panel provides sufficient power, the pump goes through the alignment phase by turning the rotor into the position required for start-up.
- The processor then waits until the capacitor is sufficiently charged.
- This enables a start-up with minimal power (less than one watt).

Materials of Construction

Pump Body: Lead-Free* Brass
 O-Ring: EPDM
 Bearing: Carbon/Alumina Ceramic
 Impeller: PPO
 Motor: High Efficiency ECM
 All Other Wetted Parts: Type 316 Stainless Steel
 Shaft-less, Seal-less Construction

Over-temperature Safety Device

- The ecocirc solar pump comes with an integrated over-temperature safety device which shuts off the pump electronics when reaching temperatures over 230°F.
- After reaching a critical temperature 203°F the pump will lower its speed automatically in order to avoid a total shutdown.

Technical Data

Motor Design: Electronically commutated spherical motor with permanent magnet rotor/impeller
 Voltage: 12 - 24 Volt
 Maximum System Temperature: 203°F (95°C)
 Maximum Pressure: 150 PSI
 Power Consumption*: Min. start-up power consumption less than 1 Watt, max. power consumption 22 Watts
 Current Draw: 0.25 - 1.46 A
 Acceptable Media: Potable hot water recirculation, heating water, water/glycol mixtures, other media on request**
 Environment: IP 42
 Insulation Class: Class F

* Power consumption and start may vary in different installations. **Please check pump performance with more than 20% glycol.

Available Models

Model	Part Number	Description	Weight
e ³ -SC6S	6055B2000	Lead-Free Brass* Solar Circulator 1/2" Sweat	2 lbs.
e ³ -SC6N	6055B2001	Lead-Free Brass* Solar Circulator 1/2" NPT	2 lbs.
e ³ -SC4U	6055B2002	Lead-Free Brass* Solar Circulator 1/2" Union Sweat**	2 lbs.

*CSA certified to NSF/ANSI 372 that product contains less than 0.25% lead content by weight on wetted surface.

** Built-in ball check valve and purge valve.

CIRCULATORS Bell & Gossett Cast Iron Wet Rotor Circulators / NRF

Description

A residential or light commercial, maintenance free, axial flanged, in-line, cast iron, wet rotor circulation pump for hydronic heating systems. UL and cUL Listed.

Operating Data

Maximum Working Pressure: 150 PSI (10 bar)

Maximum Operating Temperature:

NRF-22 & NRF-9F/LW: 240°F (115°C)

NRF-25, NRF-33, NRF-36 & NRF-45: 225°F (107°C)

Materials of Construction

Pump Body: Cast Iron

Impeller: Noryl

Shaft: Ceramic

Bearings: Double-Sintered Carbon

Warranty

Bell & Gossett offers a warranty of 3 years from date of manufacture or 18 months from date of installation (which ever comes first) against failure as a result of defects in materials and workmanship.

Specifications

Model Number	Single Speed	Three Speed	Part Number	Flange Sizes Inches - NPT	Dimensions Inches (mm)			Standard 60 Cycle Motor Characteristics*					Shipping Weight lbs. (Kg)
					A	B	C	Watts	ø	Volts	F.L. Amps	RPM	
NRF-9F/LW	●		103267	3/4, 1, 1 1/4, 1 1/2	6 3/8 (162)	6 3/16 (157)	5 1/8 (130)	41	1	115	0.40	2800	9.3 (4.2)
NRF-22	●		103251		6 3/8 (162)	6 3/16 (157)	5 1/8 (130)	92			0.80	2940	9.3 (4.2)
NRF-25		●	103417		6 3/8 (162)	6 3/16 (157)	5 1/8 (130)	125			1.20	2950	10.4 (4.7)
NRF-33	●		103350		6 3/8 (162)	5 9/16 (141)	4 7/8 (124)	125			1.10	2950	10.4 (4.7)
NRF-36		●	103400		6 3/8 (162)	6 7/8 (175)	5 3/4 (146)	270			2.30	3300	13.1 (6.0)
NRF-45		●	103404	1, 1 1/4, 1 1/2	8 1/2 (216)	7 3/8 (187)	5 3/4 (146)	270			2.30	3300	14.5 (6.6)

NRF-9F/LW, NRF-22, NRF-25 and NRF-33 are impedance protected.

NRF-36 and NRF-45 are thermally protected.

Dimensions are approximate and subject to change. Contact factory for certified dimensions.

Single Speed NRF Circulator Performance Curves

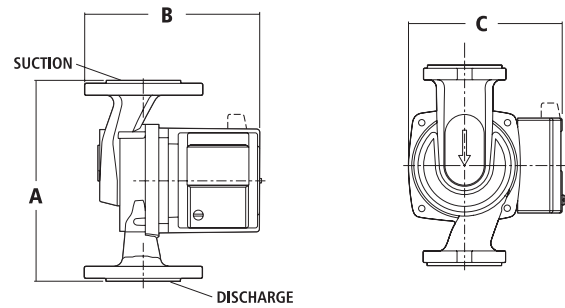
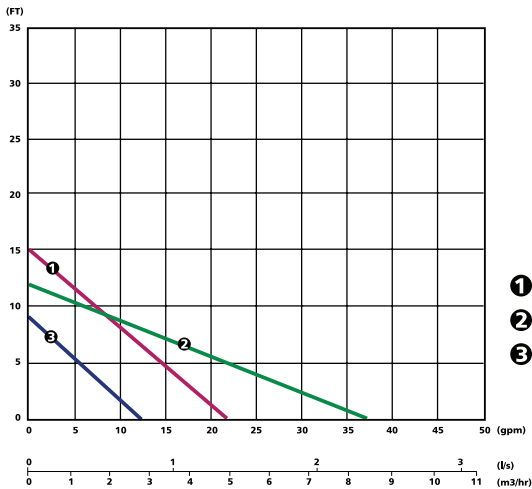

Single Speed NRF Circulators



NRF-9F/LW



NRF-22



NRF-33



CIRCULATORS Bell & Gossett Cast Iron Wet Rotor Circulators / NRF

Reliable, maintenance-free, whisper quiet wet rotor circulators designed for residential and light commercial heating systems.

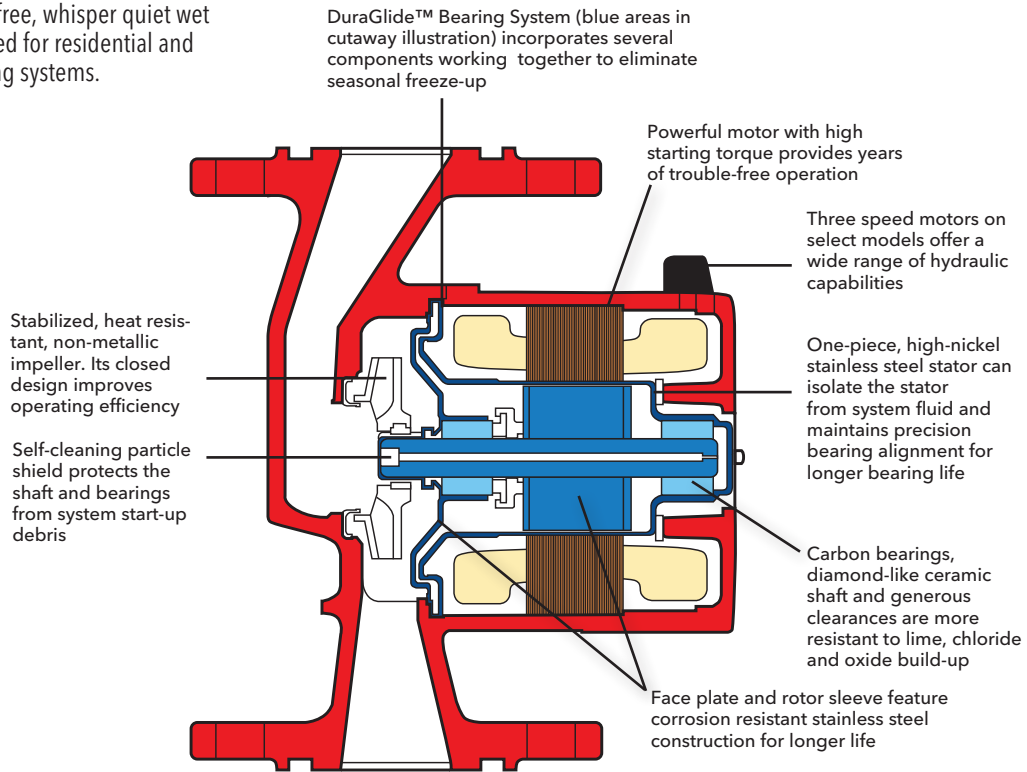

Three-Speed NRF Circulator Performance Curves

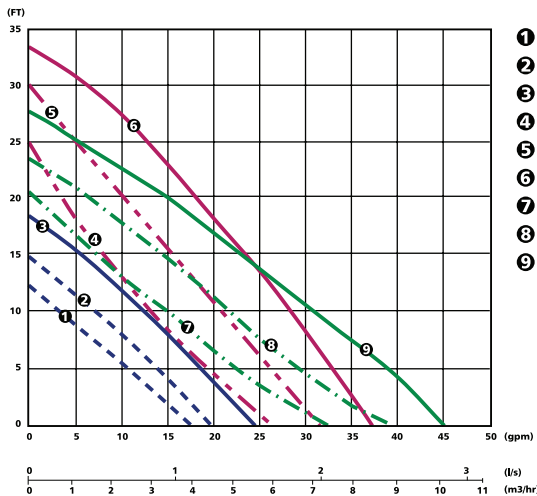

- ❶ NRF-25 Speed 1
- ❷ NRF-25 Speed 2
- ❸ NRF-25 Speed 3
- ❹ NRF-36 Speed 1
- ❺ NRF-36 Speed 2
- ❻ NRF-36 Speed 3
- ❼ NRF-45 Speed 1
- ❽ NRF-45 Speed 2
- ❾ NRF-45 Speed 3

Optional Zone Pump Relay Control



The ZoneTrol II AZ-1A is a single zone pump relay that turns the pump and boiler on when the thermostat calls for heat. The AZ-1A is ideal when adding a zone to an existing system and can be daisy-chained together to control multiple zones (See page 25.)

Three-Speed NRF Circulators



NRF-25



NRF-36



NRF-45

CIRCULATORS Lead-Free Wet Rotor Circulators for Potable Water / NBF & SSF

Description

A residential or light commercial, maintenance-free, in-line, lead-free* bronze or stainless steel, wet rotor circulator for potable water systems and other applications. Flanged, union or sweat models available. UL and cUL listed.

Operating Data

Maximum Working Pressure: 150 PSI (10 bar)
 Maximum Operating Temperature:
 NBF-25, NBF-33, NBF-36, NBF-45: 225°F (107°C)
 All Others: 230°F (110°C)

Materials of Construction

Pump Body NBF: 100% Lead-Free* Bronze
 SSF: Stainless Steel
 Impeller: Noryl
 Shaft: Ceramic
 Bearings: Double-Sintered Carbon

Warranty

Bell & Gossett offers a warranty of three years from date of manufacture or 18 months from date of installation (which ever comes first) against failure as a result of defects in materials and workmanship.

*CSA certified to NSF/ANSI 372 that product contains less than 0.25% lead content by weight on wetted surface.



SSF-9



NBF-9

Cross Reference

BELL & GOSSETT	GRUNDFOS†	TACO††
NBF-8S/LW	UM 15-10B5	003B
NBF-10S/LW	UP 15-18B5	006B
NBF-18S	UP 15-42B5	-
SSF-22	UP25-64SF	007B
NBF-25	UPS15-58	00R-MS
NBF-33	-	0010B
NBF-36	UP26-96BF	0011B
	UP26-99BF	0013B
	UP26-64SF	0014B
NBF-45	UP43-75BF	-

†Grundfos is a registered trademark of Grundfos Pumps Corp.

††Taco is a registered trademark of Taco, Inc.

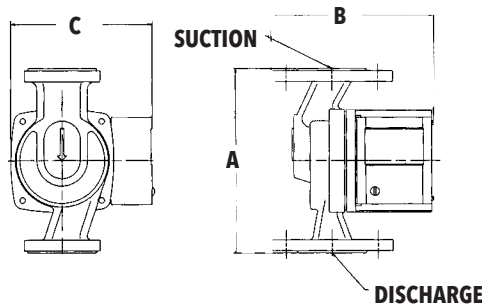

Specifications

Model Number	Part Number	Connections	Dimensions Inches (mm)			Standard 60 Cycle Motor Characteristics*					Shipping Weight lbs. (Kg)
			A	B	C	Watts	ø	Volts	F.L. Amps	RPM	
NBF-8S/LW	103257LF	1/2" Sweat	5 (127)	5 7/32 (132)	4 7/8 (124)	39	1	115	0.39	2800	9.0 (4.1)
NBF-9U/LW	103258LF	Union**	6 1/8 (156)	5 1/16 (129)	4 7/8 (124)	41			0.40	2800	9.3 (4.2)
NBF-10S/LW	103259LF	1/2" Sweat	5 (127)	5 7/32 (132)	4 7/8 (124)	55			0.46	2800	9.0 (4.1)
NBF-12F/LW	103260LF	Flange 3/4, 1 1/4, 1 1/2	6 3/8 (162)	5 9/16 (141)	4 7/8 (124)	55			0.48	2800	9.5 (4.3)
NBF-12U/LW	103261LF	Union**	6 1/8 (156)	5 1/16 (129)	4 7/8 (124)	55			0.48	2800	9.3 (4.2)
NBF-18S	103316LF	1/2" Sweat	5 (127)	5 7/32 (132)	4 7/8 (124)	90			0.74	3000	9.0 (4.1)
NBF-22	103252LF	Flange 3/4, 1 1/4, 1 1/2	6 3/8 (162)	5 9/16 (141)	4 7/8 (124)	92			0.80	2940	9.5 (4.3)
NBF-22U	103255LF	Union**	6 1/8 (156)	5 1/16 (129)	4 7/8 (124)	92			0.80	2940	9.3 (4.2)
NBF-25	103418LF	Flange 3/4, 1 1/4, 1 1/2	6 3/8 (162)	6 3/16 (157)	5 1/8 (130)	125			1.10	2950	10.4 (4.7)
NBF-33	103351LF	Flange 3/4, 1 1/4, 1 1/2	6 3/8 (162)	6 3/16 (157)	5 1/8 (130)	125			1.10	2950	10.4 (4.7)
NBF-36	103401LF	Flange 3/4, 1 1/4, 1 1/2	6 3/8 (162)	6 7/8 (175)	5 3/4 (147)	270			2.30	3300	13.1 (6.0)
NBF-45	103405LF	Flange 1 1/4, 1 1/2	8 1/2 (216)	7 3/8 (187)	5 3/4 (147)	270			2.30	3300	14.5 (6.6)
SSF-9U/LW	103360LF	Union**	6 1/8 (156)	5 1/16 (129)	4 7/8 (124)	41			0.40	2800	9.3 (4.2)
SSF-12F/LW	103358LF	Flange 3/4, 1 1/4, 1 1/2	6 3/8 (162)	5 9/16 (141)	4 7/8 (124)	55			0.48	2800	9.5 (4.3)
SSF-12U/LW	103361LF	Union**	6 1/8 (156)	5 1/16 (129)	4 7/8 (124)	55			0.48	2800	9.3 (4.2)
SSF-22	103357LF	Flange 3/4, 1 1/4, 1 1/2	6 3/8 (162)	5 9/16 (141)	4 7/8 (124)	92			0.80	2940	9.5 (4.3)
SSF-22U	103362LF	Union**	6 1/8 (156)	5 1/16 (129)	4 7/8 (124)	92			0.80	2940	9.3 (4.2)

* Impedance protected

** Union Connections are available in 3/4" NPT, 1/2" sweat & 3/4" sweat.

CIRCULATORS Lead-Free Wet Rotor Circulators for Potable Water / NBF & SSF – continued

Single Speed-NBF/SSF 60 HZ Performance Curve

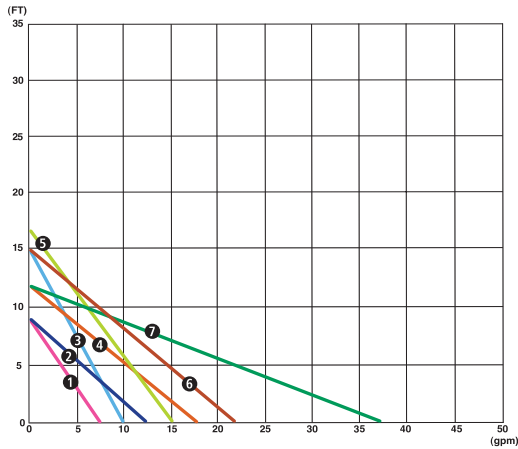

- 1 NBF-8S/LW
- 2 NBF-9U/LW
SSF-9U/LW
- 3 NBF-10S/LW
- 4 NBF-12U/LW
SSF-12U/LW
NBF-12F/LW
SSF-12F/LW
- 5 NBF-18S
- 6 NBF-22
SSF-22
NBF-22U
SSF-22U
- 7 NBF-33

Three Speed-NBF 60 HZ Performance Curve

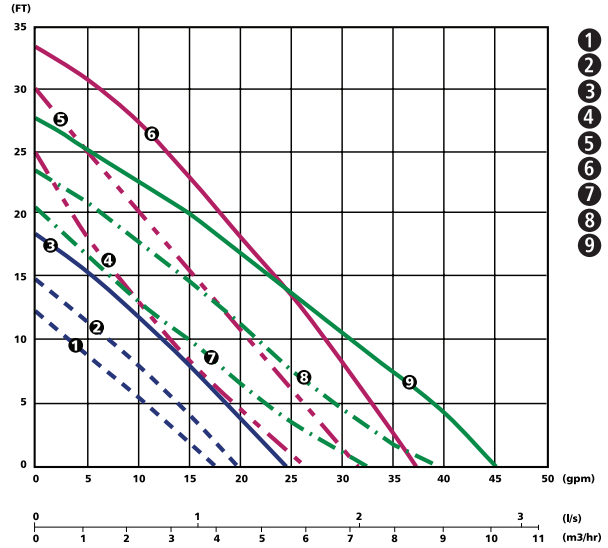

- 1 NBF-25 Speed 1
- 2 NBF-25 Speed 2
- 3 NBF-25 Speed 3
- 4 NBF-36 Speed 1
- 5 NBF-36 Speed 2
- 6 NBF-36 Speed 3
- 7 NBF-45 Speed 1
- 8 NBF-45 Speed 2
- 9 NBF-45 Speed 3

CIRCULATORS Series LR™ Maintenance-Free Circulators

Materials of Construction

Pump Body: LR-20WR: Cast Iron
LR-15BWR: Lead-Free* Bronze

Impeller: Noryl®

Shaft: Ceramic

Bearings: Carbon

*CSA certified to NSF/ANSI 372 that product contains less than 0.25% lead content by weight on wetted surface.

Operating Data

Maximum Working Pressure: 150 PSI (10 bar)

Maximum Operating Temperature: 225°F (107°C)



LR-15B

LR-20

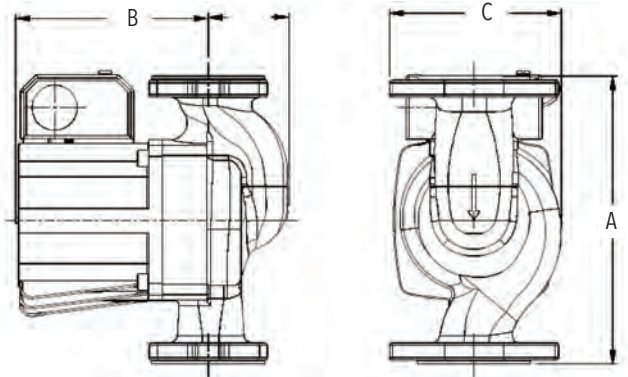
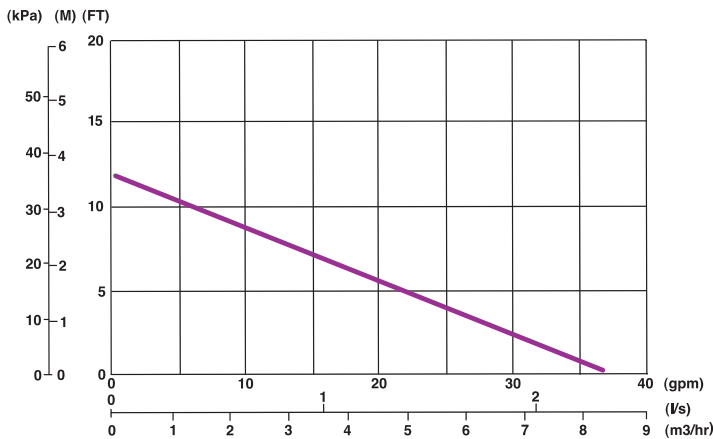

Specifications

Model Number	Part Number	Pump Body Material	Flange Sizes Inches-NPT	Dimension Inches (mm)			Standard 60Hz Motor Characteristics*				Approx. Shpg. Wt. lbs (Kg)	
				A	B	C	Watts	Ø	F.L. Amps	FL Amps		RPM
LR-20WR	106507	Cast Iron	3/4, 1, 1-1/4, 1-1/2	6-3/8 (162)	6 (152)	3-7/8 (98)	125	1	115	1.10	2950	10.4 (4.7)
LR-15BWR	106514LF	Bronze	3/4, 1, 1-1/4, 1-1/2									

CIRCULATORS Maintenance-Free Circulators

SERIES PL™ a superior alternative to large wet rotor pumps



PL-30, 36, 45, 50, 55

PL-75, 130

Operating Data

Maximum Working Pressure: 150 PSI (10.3 bar)
Maximum Operating Temperature: 225°F (107°C)

Materials of Construction

Booster Body: Cast Iron or Lead-Free* Bronze
Face Plate: Stainless Steel
Impeller: 30% Glass Filled Noryl® (PL-55 & PL-130): Glass Filled PPS
Shaft: Carbon Steel (PL-55 & PL-130): Stainless Steel
Shaft Sleeve: Stainless Steel (PL-55 & PL-130): None
Seal: Mechanical, Carbon on Silicon Carbide
Motor Bearings: Sealed Precision Steel Ball Bearing Permanently Lubricated
Motor Type: ODP
Elastomers: EPDM

*CSA certified to NSF/ANSI 372 that product contains less than 0.25% lead content by weight on wetted surface.

Specifications

Cast Iron		Lead Free		Flange Sizes Inches - NPT	Motor Characteristics*				Dimension Inches (mm)@ 60Hz					Approx. Shpg. Wt. lbs (Kg)
Model Number	Part Number	Model Number	Part Number		HP	Ø	Voltage	RPM	A	B	C	D	E	
PL-30	1BL012	PL-30B	1BL013LF	3/4", 1", 1-1/4", 1 1/2"	1/12th	1	115	2650	8-5/8" (219)	6-3/8" (162)	7-1/8" (181)	4-3/16" (106)	4-3/8" (111)	11.6 (5.3)
PL-36	1BL001	PL-36B	1BL003LF	3/4", 1", 1-1/4", 1 1/2"	1/6th			3300	8-5/8" (219)	6-3/8" (162)	7-1/8" (181)	4-3/16" (106)	4-3/8" (111)	13.1 (6.0)
PL-45	1BL002	PL-45B	1BL004LF	1", 1-1/4", 1-1/2"	1/6th			3300	9-1/8" (232)	8-1/2" (216)	7-1/4" (184)	4-5/8" (117)	4-1/2" (114)	14.5 (6.6)
PL-50	1BL016	PL-50B	1BL017LF	1", 1-1/4", 1-1/2"	1/6th			3300	9-1/8" (232)	8-1/2" (216)	7-1/4" (184)	4-5/8" (117)	4-1/2" (114)	14.5 (6.6)
PL-55	1BL032	PL-55B	1BL068LF	3/4", 1", 1-1/4", 1 1/2"	2/5th			3250	9-9/16 (243)	6-3/8" (162)	7-15/16" (202)	4-3/16" (106)	4-3/4" (121)	13.1 (6.0)
PL-75	1BL034	PL-75B	1BL035LF	2"	1/6th			3400	9-15/16 (252)	8-1/2" (216)	7-3/8" (187)	5-3/16" (132)	4-5/8" (117)	18.5 (8.4)
PL-100	1BL134	PL-100B	1BL136LF	1", 1-1/4", 1-1/2"	2/5th			3250	9-1/8" (232)	8-1/2" (216)	7-1/4" (184)	4-5/8" (117)	4-1/2" (114)	14.5 (6.6)
PL-130/2"	1BL063	PL-130B/2"	1BL065LF	2"	2/5th			3200	10-3/4" (273)	8-1/2" (216)	8-1/4" (210)	5-3/16" (132)	5-1/8" (130)	22 (10)
PL-130/3"	1BL070	PL-130B/3"	1BL072LF	3"	2/5th			3200	10-3/4" (273)	8-1/2" (216)	8-1/4" (210)	6" (130)	5-1/8" (130)	27 (12.2)

* 230/60/1 motors available upon request. Models PL-75 and PL-130 have four bolt hole flange connection, all others have two bolt hole flange connectors. Dimensions are approximate and subject to changes. Contact factory for certified dimensions.

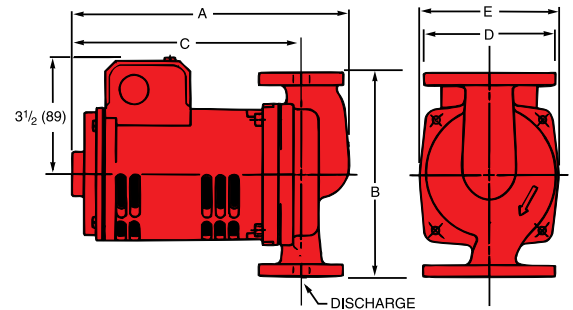
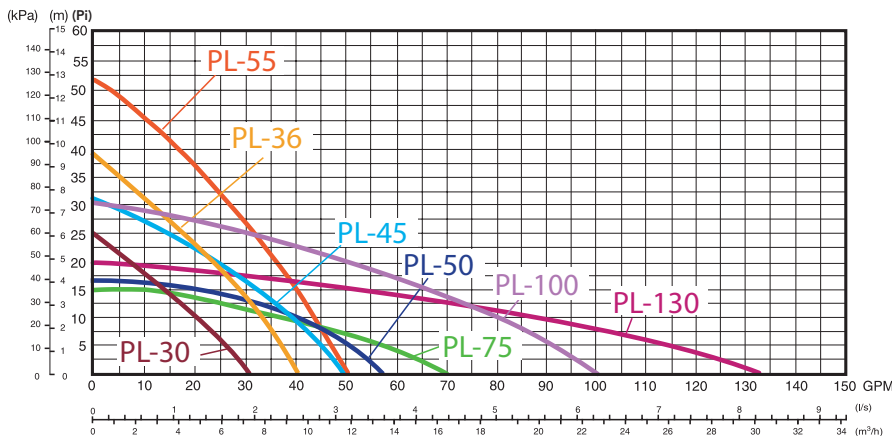

- 1 B&G's powerful, dry-motor design delivers exceptional performance. . . . 25% more efficient than competition.
- 2 Precision-machined and balanced alloy steel rotor for superior performance.
- 3 Quick-connect wire nut leads and dual knock-outs make for fast, sure hook-ups.
- 4 Solid "Stiff-Shaft" design is constructed of high-strength alloy steel impervious to cracking caused by thermal stresses.
- 5 XL-11™ Precision-Crafted Bearing System... is permanently oil lubricated... completely maintenance free...precisely positioned for long-life and isolated for quiet operation.
- 6 Advanced close-coupled design increases pump life and efficiency, assures dependable seasonal start-ups and can easily handle difficult water conditions.
- 7 Tough, durable seal system features a carbon/silicon carbide seal on a stainless steel shaft sleeve for long life and rugged operation.
- 8 Double sided I-Seal™ design for optimum efficiency.

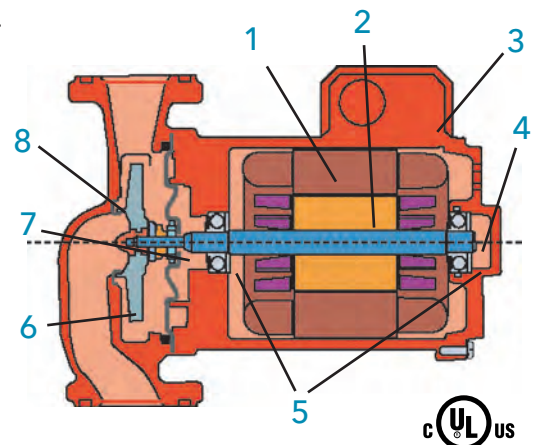

CIRCULATORS Oil Lubricated Circulators Three-Piece

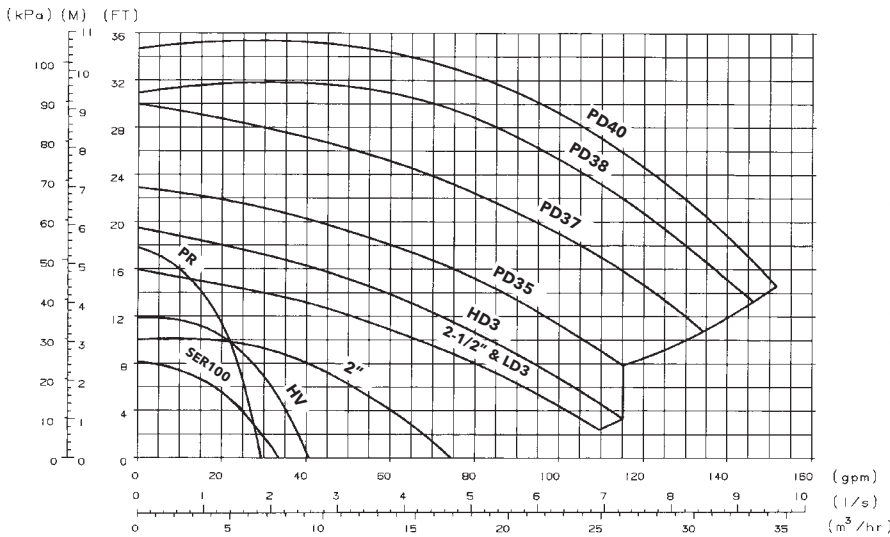

Operating Data

Maximum Working Pressure: 125 PSI (8.6 bar)
 Maximum Operating Temperature:
 Standard Seal: 225°F (107°C) continuous
 Special Seals: 250°F (121°C) continuous

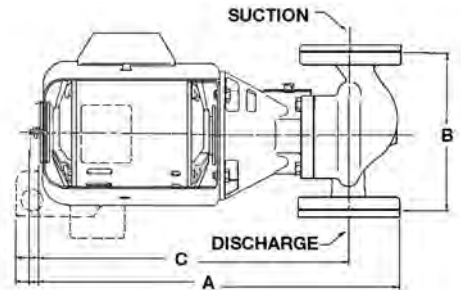

Specifications

Model Number	Cast Iron		Bronze		Flange Sizes Inches - NPT	Motor Characteristics*			Dimension Inches (mm)@ 60Hz			Approx. Shpg. Wt. lbs (Kg)	
	Model Number	Part Number	Model Number	Part Number		HP	Ø	Voltage	A	B	C	Cast Iron	Bronze
Series 100	100 NFI	106189	100 AB	106192LF	3/4, 1, 1-1/4, 1 1/2	1/12	1	115/230	14 7/8 (378)	6 3/8 (162)	12 3/4 (324)	20 (9)	21 (10)
	100 BI	106190	100 BNFI	106197LF									
Series PR	PR	102206	PR AB	102208LF	3/4, 1, 1-1/4, 1 1/2	1/6	1	115/230	15 1/4 (387)	8 1/2 (216)	12 3/4 (324)	30 (14)	32 (15)
	PR BI	102207		102231LF									
Series HV	HV NFI	102210	HV AB	102213LF	1, 1-1/4, 1 1/2	1/6	1	115/230	15 3/8 (391)	8 1/2 (216)	13 (330)	28 (13)	30 (14)
	HV BI	102230	HV BNFI	102213LF									
2"	2 NFI	102214	2AB	102233LF	2	1/6	1	115/230	16 5/8 (422)	8-1/2 (216)	14 (356)	36 (16)	39 (18)
	2 BI	102232	2 BNFI	102217LF									
2 1/2"	2 1/2	102218	2 1/2 AB	102220LF	2 1/2	1/4	1	115/230	17 1/4 (438)	10 (254)	14 (356)	54 (24)	58 (26)
	2 1/2 BI	102219											
LD3	LD3	102222	LD3 AB	102224LF	3	1/4	1	115/230	17 1/4 (438)	10 (254)	14 (356)	53 (24)	57 (26)
	LD3 BI	102223											
HD3	HD3	102226	HD3 AB	102228LF	3	1/3	1	115/230	17 1/2 (445)	10 (254)	14 1/4 (362)	55 (25)	59 (27)
	HD3 BI	102227											
PD-35S	PD35S	105089	PDB35S	105092LF	3	1/2	1	115/230	20 1/4 (514)	12 (305)	16 7/8 (429)	75 (34)	80 (36)
	PD35S BI	105090											
PD-35T	PD35T	105093	PDB35T	105096LF	3	1/2	3	208-230/460	20 1/4 (514)	12 (305)	16 7/8 (429)	75 (34)	80 (36)
	PD35T BI	105094											
PD-37S	PD37S	105097	PDB37S	105100LF	3	3/4	1	115/230	20 1/4 (514)	12 (305)	16 7/8 (429)	75 (34)	80 (36)
	PD37S BI	105098											
PD-37T	PD37T	105101	PDB37T	105104LF	3	3/4	3	208-230/460	20 1/4 (514)	12 (305)	16 7/8 (429)	75 (34)	80 (36)
	PD37T BI	105102											
PD-38S	PD38S	105121	PDB38S	105123LF	3	1	1	115/230	22 3/4 (578)	14-1/2 (368)	19 (483)	128 (58)	138 (63)
	PD38S BI	105122											
PD-38T	PD38T	105133	PDB38T	105135LF	3	1	3	208-230/460	24 (610)	14-1/2 (368)	20 1/4 (514)	125 (57)	135 (61)
	PD38T BI	105134											
PD-40S	PD40S	105151	PDB40S	105153LF	3	1 1/2	1	115/230	24 3/4 (629)	14-1/2 (368)	21 (533)	130 (59)	140 (64)
	PD40S BI	105152											
PD-40T	PD40T	105137	PDB40T	105139LF	3	1 1/2	3	208-230/460	21 7/8 (556)	14-1/2 (368)	18 1/8 (460)	127 (58)	137 (62)
	PD40T BI	105138											

PD-38 and PD-40 are ball bearing, maintenance-free design.

*CSA certified to NSF/ANSI 372 that product contains less than 0.25% lead content by weight on wetted surface.

**Speed motors available upon request. Dimensions are approximate and subject to changes.

Contact factory for certified dimensions

- B&G Motor – The heart of the booster.**
The finest circulator motor available. Sleeve bearing, oil lubricated with replaceable resilient motor mounts. B&G motors are designed and manufactured specifically for the B&G boosters.
- Noise dampening coupler.** B&G's own flexible spring design adds to quiet operation. Do not accept a substitute.
- Long bronze sleeve bearings maintain exact shaft alignment.** Provides for constant circulation of oil over bearing surfaces.
- Precision ground pump shaft is oversized to provide large bearing surfaces.** Hardened integral thrust collar minimizes end-thrust to ensure long seal and bearing life.
- The B&G mechanical seal is designed to withstand the wide range of water temperatures, pressures, additives and dissolved solids common in hydronic systems.**
- Centrifugal impeller prevents accumulation of air at seal faces to assure long life.** Close impeller/body tolerances minimize water slippage and maximize efficiency.

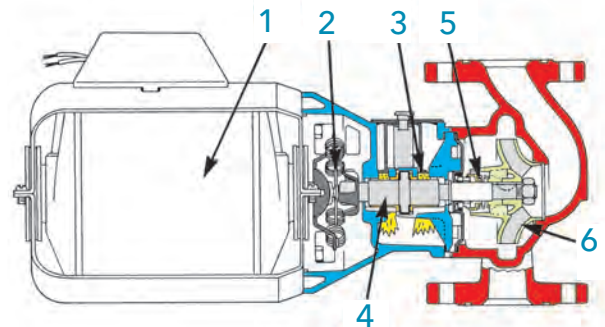

CIRCULATORS Series e-60 In-Line Mounted Centrifugal Pump Now Available with ECM Motor

Description

A maintenance-free, in-line, cast iron or cast bronze centrifugal pump with optional built-in simple variable speed capability for some sizes.

Designed for a variety of applications

- Hydronic heating & cooling systems
- Domestic water
- Fluid transfer
- Header/boiler recirculation

Product Features

- Maintenance-free pump and motor design
- Unitized internal self-flushing mechanical seal
- XL11® permanent lubrication system
- Factory tested for quality
- ISO 9001 certified
- Durable neoprene coupling
- Compact design
- Easy installation
- Wide range of standard sizes
- Three-year B&G warranty

Materials of Construction

Body: Cast Iron (Bronze Fitted) or Cast Bronze (All Bronze)
 Impeller: Cast Bronze
 Motor Shaft: Alloy Steel
 Pump Shaft: Steel
 Volute Gasket: Cellulose Fiber
 Shaft Sleeve: Copper Alloy
 Bracket: Cast Iron with Stainless Steel Face Plate: 304 Stainless Steel
 Mechanical Seal: EPR/Carbon/SIC Standard: -10°F to 225°F

Operating Data

Maximum working pressure: 175 PSI
 Working fluid temperature: -10°F to 225°F
 Temperatures up to 250°F (121°C) with optional Seal

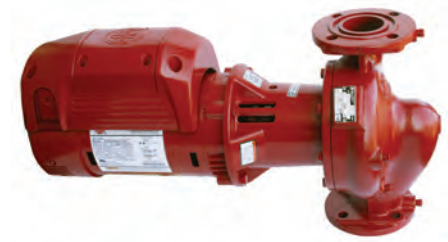

Shown with optional ECM motor

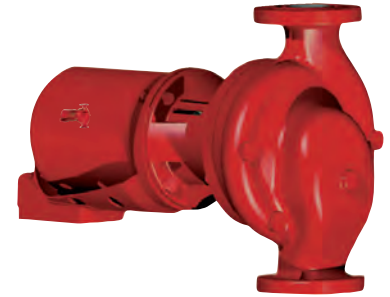

Unitized internal self-flushing seal

Bell & Gossett's open seal chamber design provides superior flow circulation around the seal faces, resulting in reduced heat buildup, increased particle removal and superior seal-face flushing. The one-piece seal design minimizes internal shear stresses and improves seal alignment, lengthening seal life and reducing friction. These design features contribute to long, reliable seal performance.

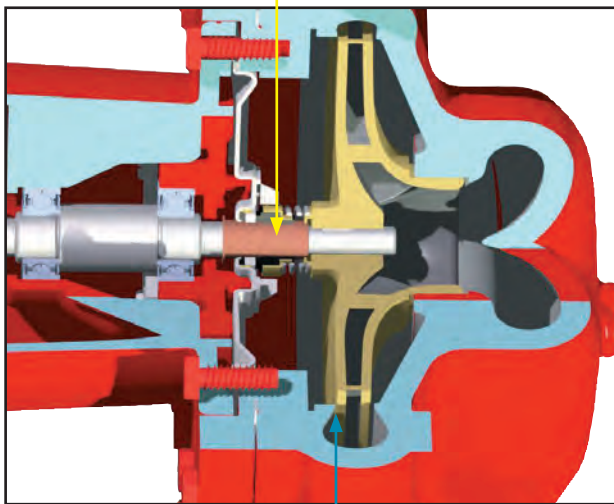

Impeller

State-of-the-art hydraulically balanced impellers and resilient-mounted motors provide smooth, quiet operation.

Series e-60 with ECM Motor Pump is 5% quieter than standard Series e-60

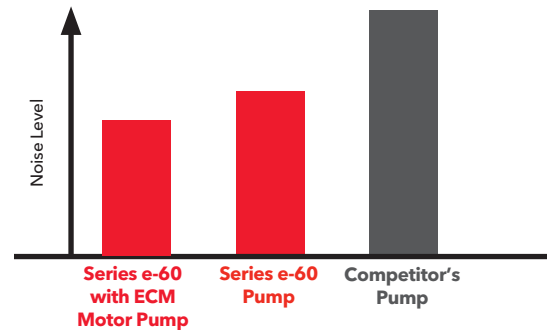

Quiet operation

The XL-11® Precision-Crafted Bearing System, advanced fluid passage design and B&G permanently lubricated motor come together to deliver smooth, quiet, maintenance-free performance.

Series e-60 ECM Hydraulic Performance Curves

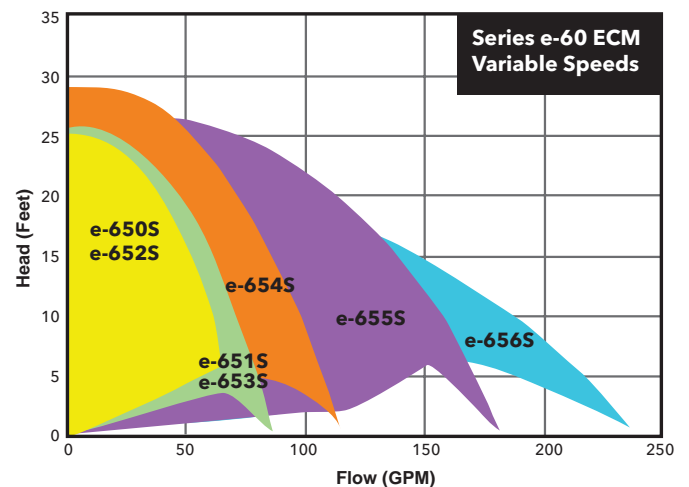

CIRCULATORS Series e-60 In-Line Mounted Centrifugal Pump

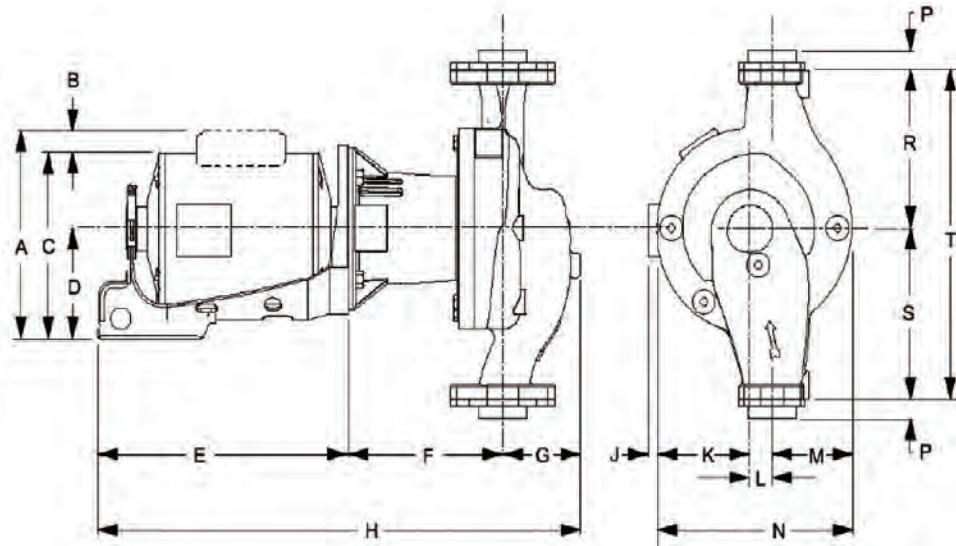
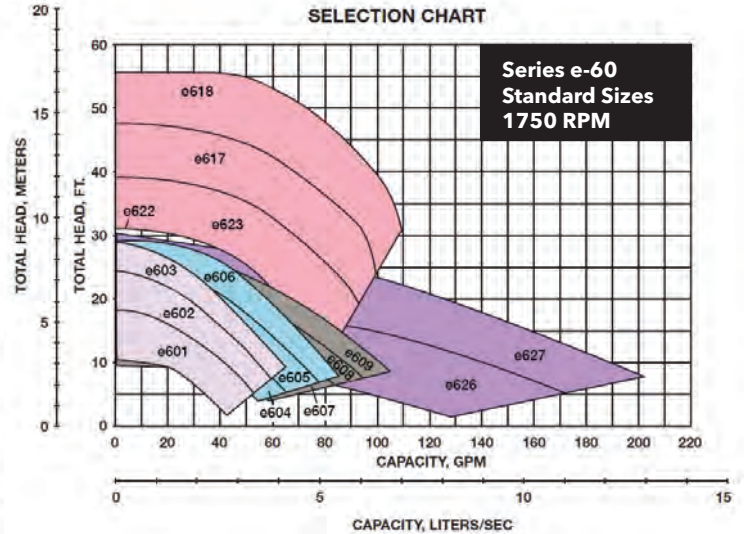
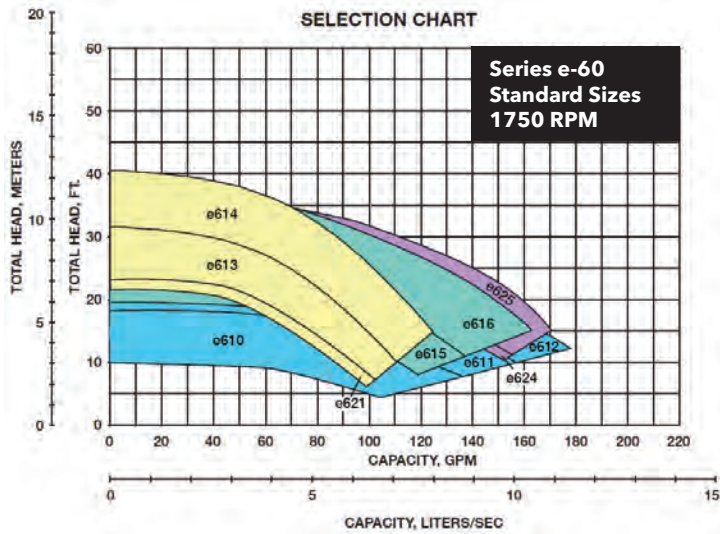

Specifications

Model	Suction and Discharge Size Inches NPT	Pump Dimension in Inches (mm)									
		F	G	K	L	M	N	P	R	S	T
e601, e602 & e603	1	6-7/16 (164)	3-7/16 (87)	3-5/8 (92)	1-3/8 (35)	2-1/2 (64)	7-1/2 (190)	3/4 (19)	5 (127)	6 (152)	11 (279)
e604, e605 & e606	1-1/4	6-7/16 (164)	3-7/16 (87)	3-5/8 (92)	1-3/8 (35)	2-1/2 (64)	7-1/2 (190)	3/4 (19)	5 (127)	6 (152)	11 (279)
e607, e608 & e609	1-1/2	6-9/16 (167)	3-5/8 (92)	3-3/4 (95)	1-3/8 (35)	2-3/4 (70)	7-7/8 (200)	3/4 (19)	5 (127)	6-1/2 (165)	11-1/2 (292)
e613, e614 & e621	1-1/2	6-11/16 (170)	3-3/8 (86)	4-1/16 (103)	1 (25)	3-9/16 (90)	8-9/16 (217)	3/4 (19)	6-1/2 (165)	7 (176)	13-1/2 (343)
e617, e618, e622 & e623	1-1/2	9-3/8 (238)	3-1/4 (83)	4-5/8 (117)	1 (25)	3-7/8 (98)	9-1/2 (241)	3/4 (19)	6-1/2 (165)	7 (176)	13-1/2 (343)
e610, e611 & e612	2	6-11/16 (164)	3-3/4 (95)	3-3/4 (95)	1-3/8 (35)	2-7/8 (73)	8 (203)	13/16 (21)	5 (127)	6-1/2 (165)	11-1/2 (292)
e615, e616	2	6-15/16 (170)	3-1/2 (89)	4-3/8 (111)	1 (25)	4 (102)	9-3/8 (238)	13/16 (21)	6-1/2 (165)	7 (176)	13-1/2 (343)

Maximum working pressure 175 PSI (12 Bar)

FLANGES Check-Trol™ Isolation Flow Control Flange

Description

The Check-Trol flange is a combination isolation valve, flow control valve, and companion flange for circulators. The ball valve allows the circulator to be removed from the system without draining the system. The internal spring check prevents gravity circulation. Free floating companion flange makes pump installation a snap.

Operating Data

Maximum Working Pressure: 150 PSI (10 bar)
Maximum Operating Temperature: 200°F (93°C)

Materials of Construction

Valve Body: Lead-Free* Brass
Flange: Chrome Plated Steel
Ball: Chrome Plated Lead-Free* Brass
Packing: PTFE
Seat Ring: PTFE
Stem: Lead-Free* Brass
Spring Check: Nitrile, Acetal, Stainless Steel

*CSA certified to NSF/ANSI 372 that product contains less than 0.25% lead content by weight on wetted surface.

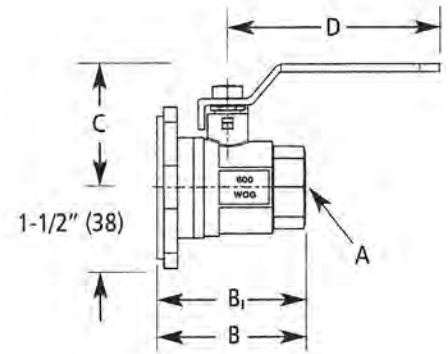
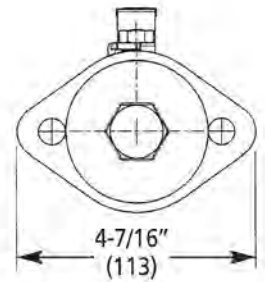
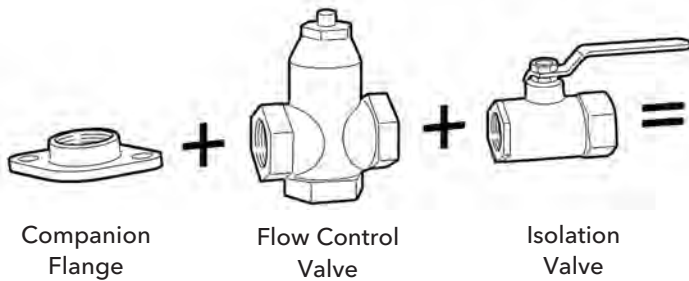

Specifications

Model Number	Size Inches	Use with Following Circulators*	Dimensions - Inches (mm) Following Circulators					Approx. Shpg. Wt. lbs. (Kg)
			A	B	B ₁ **	C	D	
101231LF	3/4" NPT x Flange	ecocirc auto and vario	3/4" NPT	3-7/64" (79)	2-27/64" (61.5)	2" (50.5)	4-23/32" (120)	3.4 (1.5)
101232LF	1" NPT x Flange	ecocirc XL 20-35, 36-45, 55-45	1" NPT	3-15/16" (100)	2-57/64" (73.3)	2-5/32" (54.7)	4-23/32" (120)	4.4 (2.0)
101233LF	1-1/4" NPT x Flange		1-1/4" NPT	4-25/32" (121.4)	3-19/64" (84)	3" (76.2)	6-7/32" (158)	6.3 (2.8)
101245LF	1-1/2" NPT x Flange	NRF/NBF/SSF Wet Rotors*	1-1/2" NPT	4-27/32" (122.9)	3-23/64" (85.5)	3" (76.2)	6-7/32" (158)	6.6 (3.0)
101236LF	3/4" SWT x Flange		3/4" SWT	3-21/64" (84.5)	2-41/64" (67)	2" (50.5)	4-23/32" (120)	3.4 (1.5)
101237LF	1" SWT x Flange	Series PL-30, PL-36, PL-55, PL-100	1" SWT	4-1/64" (102)	3" (75.3)	2-5/32" (54.7)	4-23/32" (120)	4.2 (1.9)
101238LF	1-1/4" SWT x Flange		1-1/4" SWT	4-55/64" (123.4)	3-25/64" (86)	3" (76.2)	6-7/32" (158)	5.9 (2.7)
101247LF	1-1/2" SWT x Flange	Series 100, PR and LR	1-1/2" SWT	5-1/64" (127.4)	3-35/64" (90)	3" (76.2)	6-7/32" (158)	6.5 (3.0)

* Not for use with NRF/NBF-45.

Dimensions and weights are approximate and subject to change. Contact factory for certified dimensions. Check-Trol flange is sold with an isolation flange as a pair.

** B₁ Dimension is overall length of isolation flange. The part numbers and shipping weights are for one Check-Trol flange and one isolation flange, capscrews and nuts.

ISOLATION FLANGES

Description

The isolation flange is a combination of an isolation ball valve and a companion flange for circulators. The isolation flange allows easy service or replacement of the circulator without the need to drain the system. The isolation flange fits the Bell & Gossett NRF/NBF/SSF wet rotors, Series PL, Series 100, HV, PR and LR circulators.

Operating Data

Maximum Working Pressure: 150 PSI (10 bar)
Maximum Operating Temperature: 250°F (121°C)

Materials of Construction

Valve Body: Lead-Free* Brass
Flange: Chrome Plated Steel
Ball: Chrome Plated Lead-Free* Brass
Packing: PTFE
Seat Ring: PTFE
Stem: Lead-Free* Brass

*CSA certified to NSF/ANSI 372 that product contains less than 0.25% lead content by weight on wetted surface.

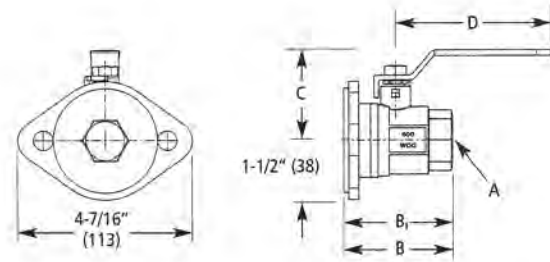

Specifications

Model Number	Size Inches	Use with Following Circulators*	Dimensions - Inches (mm)				Approx. Shpg. Wt. lbs. (Kg)
			A	B	C	D	
101221LF	3/4" NPTF IF	ecocirc auto and vario ecocirc XL 20-35, 36-45, 55-45 NRF/NBF/SSF wet rotors Series PL-30, PL-36, PL-55, PL-100 Series 100, PR and LR	3/4" NPT	2-27/64" (61.5)	2" (50.5)	4-47/64" (120)	3.2 (1.5)
101222LF	1" NPTF IF		1" NPT	2-57/64" (73.3)	2-5/32" (54.7)	4-47/64" (120)	4.1 (1.9)
101223LF	1-1/4" NPTF IF		1-1/4" NPT	3-19/64" (84)	3" (76.2)	6-7/32" (158)	5.8 (26)
101241LF	1-1/2" NPTF IF		1-1/2" NPT	3-23/64" (85.5)	3" (76.2)	6-7/32" (158)	6.1 (28)
101226LF	3/4" SWT IF		3/4" SWT	2-41/64" (67)	2" (50.5)	4-23/32" (120)	3.2 (1.5)
101227LF	1" SWT IF		1" SWT	3" (75.3)	2-5/32" (54.7)	4-23/32" (120)	3.9 (1.8)
101228LF	1-1/4" SWT IF		1-1/4" SWT	3-25/64" (86)	3" (76.2)	6-7/32" (158)	5.4 (25)
101243LF	1-1/2" SWT IF		1-1/2" SWT	3-35/64" (90)	3" (76.2)	6-7/32" (158)	6 (27)

"IF" = "Isolation Flange"

Note: Dimensions and weights are approximate and subject to change. Contact factory for certified dimensions. The part numbers and shipping weights are for two isolation flanges, capscrews and nuts.

* Not for use with NRF/NBF-45.

Companion Flanges

Flanges for Cast Iron Circulators

	Size (NPT)	Master Carton of 12 Part No.	Set of 2 Part No.
Series 100, PR NRF-22, NRF-9F/LW, NRF-33, NRF-36 PL-30, PL-36, PL-55, PL-100, ecocirc XL	3/4"	101001	101201
	1"	101002	101202
	1-1/4"	101003	101203
	1-1/2"	101004	101204
Series HV, PL-45 PL-50, NRF-45 ecocirc XL	1"	101005	101205
	1-1/4"	101006	101206
	1-1/2"	101007	101207

	Size (NPT)	Set of 2 Part No.*
PL-75, PL-130B/2" ecocirc XL 15-75	2"	101215
PL-130B/3" ecocirc XL 40-275	2-1/2"	101219
	3"	101217

*Includes Fasteners

Union Connection for NBF Circulators

	Union Connection	Set of Two	
		Model No.	Part No.
NBF-22U, NBF-12U/LW NBF-9U/LW	1/2" sweat	UC-1/2S	113203LF
	3/4" sweat	UC-3/4S	113201LF
	3/4" NPT	UC-3/4NPT	113202LF

Flanges for Bronze Circulators

	Size (NPT)	Master Carton of 12 Part No.	Set of 2 Part No.
Series 100B, PRAB, NBF-22, NBF-12F/LW, NBF-33, NBF-36 PL-30B, PL-36B, PL-100, ecocirc XLB	3/4"	101511LF	101501LF
	1"	101512LF	101502LF
	1-1/4"	101513LF	101503LF
	1-1/2"	1101514LF	101504LF
Series HV, PL-45B PL-50B, NBF-45 ecocirc XLB	1"	101515LF	101505LF
	1-1/4"	101516LF	101506LF
	1-1/2"	101517LF	101507LF

	Size (NPT)	Set of 2 Part No.*
PL-75B, PL-130B/2" ecocirc XLB 15-75	2"	101508LF
PL-130B/3" ecocirc XLB 40-275	2-1/2"	101510LF
	3"	101509LF

*Includes Fasteners



CONTROLS ecocirc® e³ SERIES TIMER

Description

To increase the overall efficiency of a domestic hot water recirculating system and to reduce water wasted while waiting for hot water, the e³ Timer can be installed on all e³ pumps. The timer is easily installed by removing the motor end cap, plugging in the timer and setting the timer schedule without any wiring. The timer can be used in 3-different selections: ON, OFF and TIMER. The ON selection operates the pump continuously, the OFF selection turns the pump OFF and the TIMER selection (depicted by a clock on the timer) turns the pump on when programmed.

Operational Limits

Power Supply: Internally powered by the e³ circulating pump
Minimum Switch Interval: 30 minutes
Run Modes: ON (Continuous), OFF (Off at all times) and TIMER (run at programmed intervals)

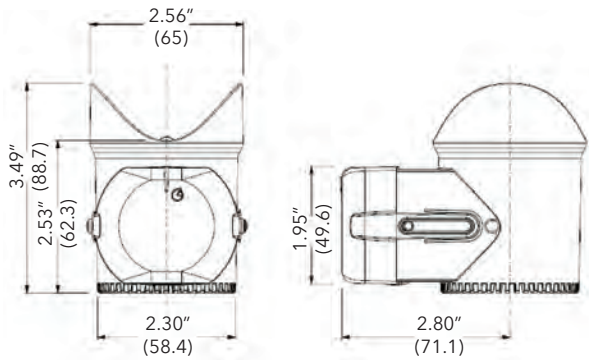

e³ Timer
(Part No. 60AABT001)



Pump not included

CONTROLS for NBF Circulators



TC-1 Automatic Timer Kit (Part No. 113210)

To increase the overall efficiency of a hot water recirculation system, the TC-1 timer control kit can be installed for use on any B&G NBF circulator. The TC-1 timer control is programmable to turn the circulator ON and OFF automatically at preset times. This permits the user to have the pump circulate hot water only during those times when high usage can be expected throughout the day. Power supply minimum interval switch is 15 minutes. Run modes maximum switch current is 16 amps.



AQS-1/2 (Part No. 113223) and AQS-3/4 (Part No. 113224) Aquastat

Designed to thermostatically turn any B&G NBF circulator ON and OFF. The AQ-1/2 or AQ-3/4 will switch the pump OFF at 120°F (48.9°C) and ON at 100°F (37.8°C). The aquastats are available in separate models that will sense the temperature for either 1/2" or 3/4" copper pipe.

AQS-1/2" clips onto 1/2" copper pipe or 3/8" steel pipe

AQS-3/4" clips onto 3/4" copper pipe or 1/2" steel pipe

RELAYS ZONETROL II AZ-1A™ Snap-On Pump Relay

Description

The ZONETROL II AZ-1A snap on relay box is an easy to install single zone pump controller that mounts directly on any Bell & Gossett wet rotor circulator NRF/NBF or Series PL booster. The AZ-1A turns the pump and boiler ON as thermostat calls for heat. Using the wire nuts provided with the package, the AZ-1A is quickly assembled onto any NRF/NBF or 1/12 to 1/6 HP Series PL. The clearly marked TT terminals for the thermostat and the XX isolated end switch terminals make the rest of the hook-up a snap. The AZ-1A can be daisy-chained together to form a maximum of three zones.

The Bell & Gossett AZ-1A is ideal for any single to three zone pump application. Or can be used when adding a zone to an existing system. There's no more need to have a pump controller hanging on the wall, simply install the AZ-1A to our NRF/NBF or Series PL circulators and you are finished.



Features

- Snap-on design allows the AZ-1A to be quickly attached to any B&G wet rotor circulator, reducing your inventory investment (no need to carry "special" circulators with factory mounted controllers)
- Clearly marked terminals make for sure, fast wiring of the system
- Compact design fits in tight locations and presents a clean professional appearance
- 100% factory tested assures reliable operation
- 5 year warranty – the best in the industry
- Daisy-Chain the AZ-1A relays to form up to three zones
- Can be used on any B&G model NRF, NBF or 1/12 to 1/6 HP Series PL pumps

Specifications

Model Number	Part Number	Transformer	Relay	Power Input
AZ-1A	109423	2.5 VA	24 VAC / 5 amps	115 V, 60 Hz, 1Ø

Dimensions (L x W x H): 2-7/8" X 3-1/4" X 2-5/8"

Approximate Shipping Weight: 0.75 lbs



The AZ-1A can be daisy-chained to form up to three zones with simplified wiring.

Low voltage wiring makes multiple relay connections a snap.

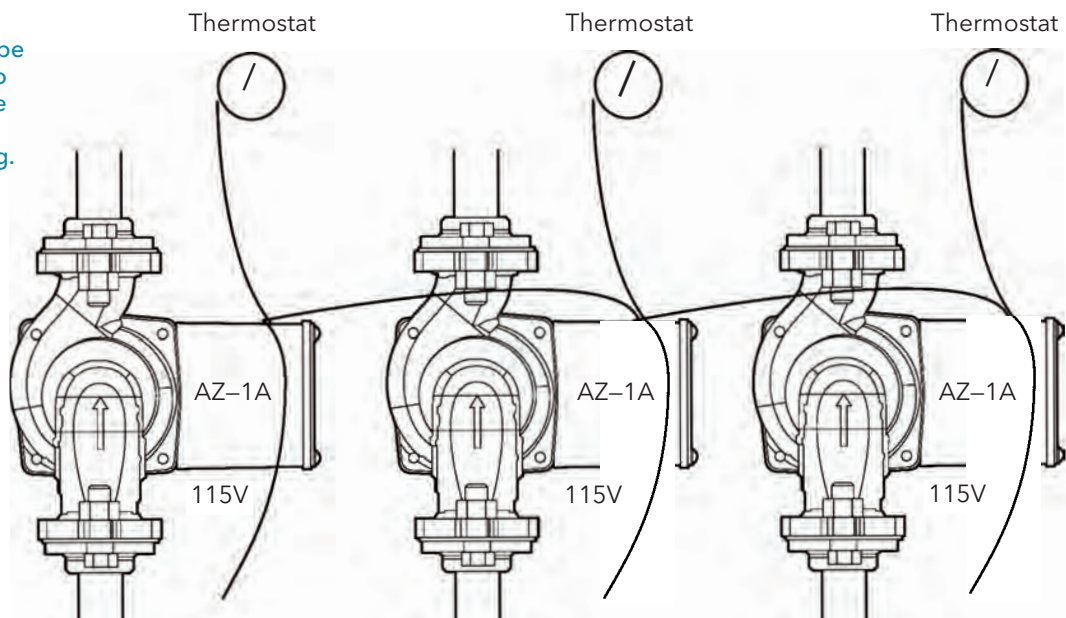

RELAYS Comfort-Trol™ Zone Control Valve

Description

Specifically designed to meet the most demanding requirements of residential, institutional and commercial hydronic heating and cooling systems.

Features

- Silent running heat motor saves power via intermittent energizing.
- Unique double torsion spring opens and closes smoothly, prevents water hammering, assures positive shut-off.
- Leaf-type stack switch with blade terminals allow fast installation and no soldering.
- Compact design and ultra-quiet operation is ideal for installation under baseboards of wherever space is limited.
- Available in 3/4" sweat body connections.
- Minimum working pressure 125 psig (862 kPa)
- Fluid temperature range 40°F (4 °C) to 240°F (115°C)



Specifications

Model Number	Part Number	Sweat Size	Voltage Rating 50/60 Hz, 1	VA Rating	Approx. Shpg. Wt. Lbs (kg)
CTS	109017	3/4"	24 Volt	15	1.0 (0.5)

BALANCE VALVES Temp Setter™ Thermostatic Valves

Description

Bell & Gossett Temp Setter thermostatic balance valves automatically control the minimum temperature of the hot water that circulates through your domestic hot water system, ensuring thermal balance throughout the system. With a stepless temperature dial, available in either °F or °C, it's fast and easy to set the desired temperature for your system.

For systems utilizing thermal bacterial disinfection, the Temp Setter valve is available with optional bypass that is independent of the valve's thermostatic element. The constant flow of high temperature fluid eradicates bacterial problems such as Legionella.

Temp Setter thermostatic balance valves are the perfect choice to safely and effectively balance your domestic hot water recirculation systems.

Materials of Construction

Body: 316 Stainless Steel
O-Rings: EPDM
Springs: 304 Stainless Steel
Thermostatic Element: Wax
Plastic Parts: POM, ABS, PC
Insulation Block: EPS

Operating Data

Maximum Working Pressure: 145 psi (1,000 kPa)
Maximum Working Temperature: 212°F (100°C)
CSA Certified for NSF/ANSI 61
Temperature Adjustment Range: 98°F - 150°F (35°C - 65°C)
Temperature Accuracy: +3.6°F (+2°C)
Insulation Block: EPS

Cv - Max: 1.27
Cv - Design: 1.44
Cv - Disinfection: 0.34
Cv - Min: .034



BALANCE VALVES Temp Setter™ Thermostatic Valves

Dimensions and Weight

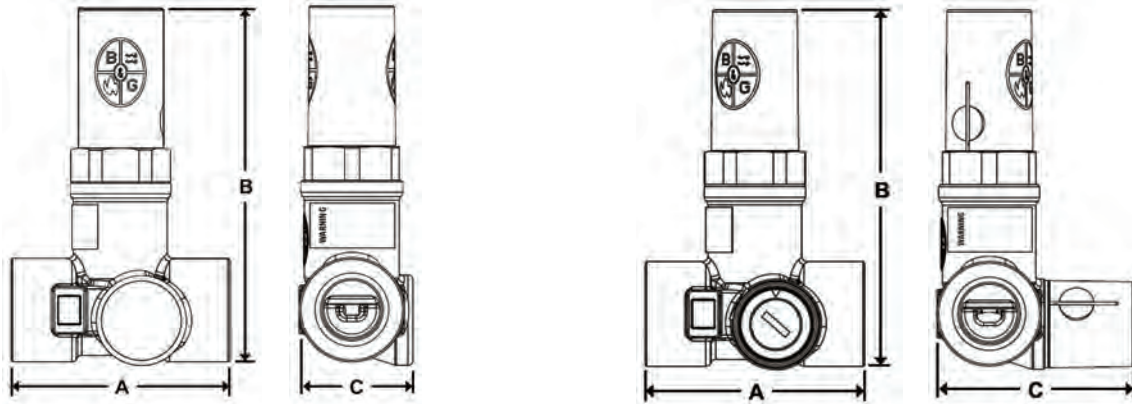

Models w/o Bypass

Models w/Manual Bypass

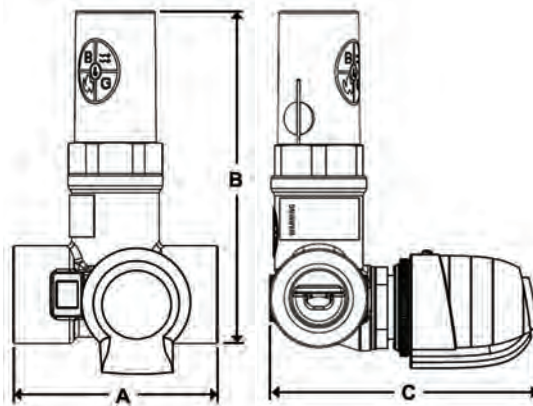

Models w/Actuated Bypass

Models w/o Bypass

Model Number	Part Number	Temperature Scale	Dimension in IN* (mm)				Approx. Weight lbs (kg)
			Size	A	B	C	
TS-1/2	117678LF	°F	0.5 (63)	2.5 (63)	4.1 (103)	1.3 (33)	1.0 (0.45)
TS-3/4	117680LF	°F	0.75 (19)	2.5 (63)	4.1 (103)	1.3 (33)	1.0 (0.45)
TS-1/2C	117682LF	°C	0.5 (63)	2.5 (63)	4.1 (103)	1.3 (33)	1.0 (0.45)
TS-3/4C	117684LF	°C	0.75 (19)	2.5 (63)	4.1 (103)	1.3 (33)	1.0 (0.45)

Models w/Manual Bypass

Model Number	Part Number	Temperature Scale	Dimension in IN* (mm)				Approx. Weight lbs (kg)
			Size	A	B	C	
TSB-1/2	117679LF	°F	0.5 (63)	2.5 (63)	4.1 (103)	2.2 (57)	1.0 (0.45)
TSB-3/4	117681LF	°F	0.75 (19)	2.5 (63)	4.1 (103)	2.2 (57)	1.0 (0.45)
TSB-1/2C	117683LF	°C	0.5 (63)	2.5 (63)	4.1 (103)	2.2 (57)	1.0 (0.45)
TSB-3/4C	117685LF	°C	0.75 (19)	2.5 (63)	4.1 (103)	2.2 (57)	1.0 (0.45)

Models w/Actuated Bypass

Model Number	Part Number	Temperature Scale	Dimension in IN* (mm)				Approx. Weight lbs (kg)
			Size	A	B	C	
TSB-1/2	N/A**	°F	0.5 (63)	2.5 (63)	4.1 (103)	3.8 (97)	1.5 (0.68)
TSB-3/4	N/A**	°F	0.75 (19)	2.5 (63)	4.1 (103)	3.8 (97)	1.5 (0.68)
TSB-1/2C	N/A**	°C	0.5 (63)	2.5 (63)	4.1 (103)	3.8 (97)	1.5 (0.68)
TSB-3/4C	N/A**	°C	0.75 (19)	2.5 (63)	4.1 (103)	3.8 (97)	1.5 (0.68)

*Dimensions are +/- 0.125". Dimensions not to be used for construction purposes unless certified

**Actuated Bypass requires Manual Bypass valve plus Actuator (PN 109518) and Actuator Adapter Kit (PN 117686)

BALANCE VALVES Lead-Free* Circuit Setter® Plus



Description

The Circuit Setter Plus and Circuit Setter Plus RF provide the perfect balance of adjustability and efficiency for potable water and HVAC systems. They are precisely calibrated for use as a presettable balance valve, variable orifice flow meter and positive shut-off service valve. They are also designed for optimal system efficiency and water conservation. The Circuit Setter Plus and Circuit Setter Plus RF can provide the perfect balancing solutions for your potable water and HVAC system.

Save time, energy and water with the lead-free Circuit Setter Plus and Circuit Setter Plus RF.

- Designed for all plumbing and HVAC systems.
- Provides equal flow throughout all circuits to conserve water and optimize system efficiency.
- Calibrated accurate flow control and measurement.
- Bi-directional design allows any installation configuration.
- Externally adjustable manual balance valve for easy adjustment.
- Reduces pump energy requirements.
- Meets or exceeds stringent codes for potable water.
- Includes memory stop indicator.
- Provides drain option.
- Provides positive shut off and isolation.
- Includes pressure/temperature ports.

Materials of Construction

Body: Brass ASTM B283-C69300*
 Ball: 304 Stainless Steel
 Seat Rings: Glass and Carbon filled TFE
 Readout Valves: Brass with EPT check valves
 Stem "O" Ring: EPDM

Maximum Working Pressure

NPT Models: 400 PSIG (2758 kPa)
 Sweat Models: See table below

Maximum Operating Temperature

-4°F (-20°C) to 250°F (121°C)

*CSA certified to NSF/ANSI 372 that product contains less than 0.25% lead content by weight on wetted surface.

Type Solder	Maximum Pressure Limitations for 1/2" - 1" with Solder Connections	
	Pressure PSI kPa	Temp °F (°C)
95-5 Tin-Antimony	300 (2068)	200 (93)
	250 (1724)	225 (107)
	200 (1379)	250 (121)

CB-1SLF



CB-1LF

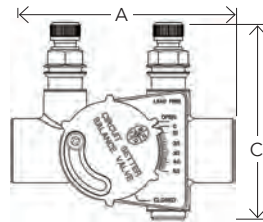
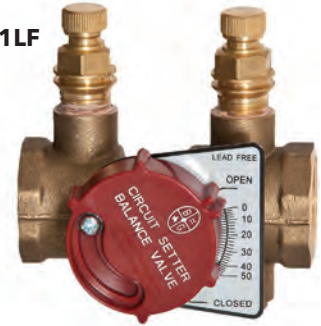

TOP VIEW 1/2"-1"

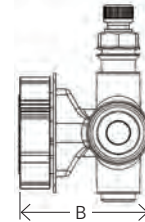

END VIEW 1/2"-1"

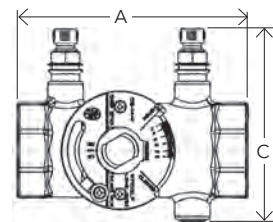

TOP VIEW 1 1/4"-3"

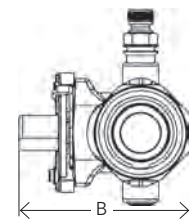

END VIEW 1 1/4"-3"

Specifications

Model Number	Part Number	Size	Connection Type	Dimensions** in Inches (mm)			Weight in lbs. (kg)
				A	B	C	
RF-1/2S LF	117410LF	1/2"	Sweat	2.91 (73.9)	1.82 (46.2)	2.85 (72.4)	0.6 (0.27)
RF-3/4S LF	117411LF	3/4"	Sweat	3.51 (89.2)	2.05 (52.1)	3.10 (78.7)	0.75 (0.34)
CB-1/2S LF	117412LF	1/2"	Sweat	2.91 (73.9)	1.82 (46.2)	2.85 (72.4)	1 (0.45)
CB-3/4S LF	117413LF	3/4"	Sweat	3.51 (89.1)	2.05 (52.1)	3.10 (78.7)	1.25 (0.6)
CB-1S LF	117401LF	1"	Sweat	4.29 (109)	2.33 (59.2)	3.33 (84.6)	2 (0.91)
CB-11/4S LF	117402LF	1 1/4"	Sweat	4.91 (124.7)	3.08 (78.2)	3.69 (93.7)	3.5 (1.6)
CB-1 1/2S LF	117403LF	1 1/2"	Sweat	5.21 (132.3)	3.27 (83)	3.95 (100.3)	3.8 (1.7)
CB-2S LF	117404LF	2"	Sweat	6.31 (160.3)	3.83 (97.3)	4.44 (112.8)	6.2 (2.8)
CB-1/2 LF	117414LF	1/2"	NPT	2.94 (74.7)	1.98 (50.3)	3.02 (76.7)	1.25 (0.6)
CB-3/4 LF	117415LF	3/4"	NPT	3.06 (77.7)	2.17 (55.1)	3.12 (79.2)	1.5 (0.7)
CB-1 LF	117416LF	1"	NPT	3.81 (96.8)	2.47 (62.7)	3.42 (86.9)	2 (0.9)
CB-1 1/4 LF	117103LF	1 1/4"	NPT	4.41 (112)	3.19 (81)	3.69 (93.7)	3.5 (1.6)
CB-1 1/2 LF	117104LF	1 1/2"	NPT	4.42 (112.3)	3.37 (85.6)	3.95 (100.3)	3.8 (1.7)
CB-2 LF	117105LF	2"	NPT	5.13 (130.3)	3.98 (101.1)	4.44 (112.8)	6.2 (2.8)
CB-2 1/2 LF	117106LF	2 1/2"	NPT	6.00 (152.4)	4.51 (114.6)	4.83 (122.7)	9 (4.1)
CB-3 LF	117107LF	3"	NPT	6.50 (165.1)	5.12 (130.0)	5.44 (138.2)	12 (5.4)

** All dimensions +/-0.125 (3.2 mm) tolerance. Dimensions are subject to change. Not to be used for construction purposes unless certified.

BALANCE VALVES Circuit Sentry™ Flo-Setter™ II

Description

The Circuit Sentry Flo-Setter II valve is a field adjustable pressure independent flow limiter that maintains set flow rates regardless of pressure fluctuations in the system; eliminates overflow.

- The unique **GPM dial** is easy to set.
Requires no instruments, charts or wheels
- Saves pump energy and improves coil efficiency
- No minimum straight pipe lengths required
- Integrated pressure /temperature ports included
- Large open flow paths for clog-free operation
- Integrated isolation/shut-off capability

Materials of Construction

Body: Brass (1/2" - 1-1/4")
Ductile Iron (1-1/2" - 2")
Flow Setting: PA6 20% Glass
Spring: Stainless Steel
Diaphragm: HNBR
O-Rings: EPDM

Maximum Working Pressure

375 PSIG (2585 kPa)

Maximum Operating Temperature

14°F (-10°C) to 248°F (110°C)

Control Range

Maximum 58 PSI (399 kPa) Delta P

Accuracy

+/- 5%



New GPM dial

Circuit Sentry Flo-Setter II

Circuit Sentry Flo-Setter II Specifications

Model Number	Part Number	Size	Connection Type	DIMENSIONS* IN INCHES (mm)					Flow Capacity in GPM (L/hr)		Approx. Weight lbs. (kg)
				A	B	C	D**	E**	Min.	Max.	
FS-1/2	117630	1/2"	NPT Female	2.9 (75)	5.6 (144)	3.4 (87)	2.24 (57)	1.12 (28)	0.26 (60)	4.75 (1,080)	1.1 (0.5)
FS-3/4	117632	3/4"	NPT Female	3.1 (79)	5.6 (144)	3.4 (87)	2.24 (57)	1.12 (28)	0.45 (102)	8.50 (1,930)	1.3 (0.6)
FS-1	117643	1"	NPT Female	3.9 (100)	6.8 (173)	4.3 (110)	2.54 (65)	1.27 (33)	0.60 (136)	10.56 (2,400)	2.8 (1.3)
FS-1-1/4	117636	1 1/4"	NPT Female	4.0 (104)	7.0 (178)	4.3 (110)	2.54 (65)	1.27 (33)	0.88 (200)	22.01 (5,000)	3.1 (1.4)
FS-1-1/2	117637	1 1/2"	NPT Female	5.4 (138)	7.9 (201)	5.1 (131)	3.60 (92)	1.80 (46)	3.17 (719)	32.58 (7,400)	6.6 (3.0)
FS-2	117638	2"	NPT Female	5.4 (138)	8.1 (207)	5.1 (131)	3.60 (92)	1.8 (46)	3.96 (900)	45.57 (10,350)	7.5 (3.4)

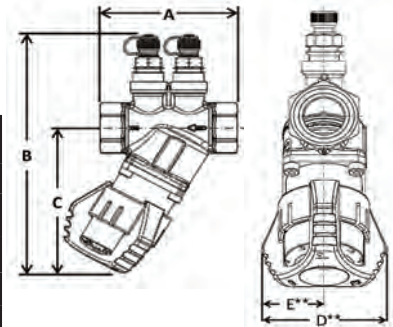

Model AF

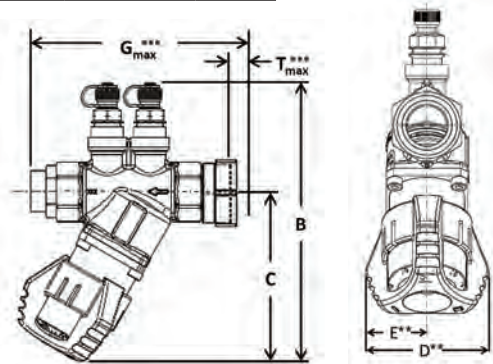

Model AF Specifications (includes union tailpiece)

Model Number	Valve Size Fixed End	Connection Fixed End	DIMENSIONS* IN INCHES (mm)						Flow Capacity in GPM (L/hr)		Approx. Weight lbs. (kg)
			B	C	D**	E**	G Max***	T Max***	Min.	Max.	
AF-1/2	1/2"	Sweat Female	5.6 (144)	3.4 (87)	2.24 (57)	1.12 (28)	5.6 (142)	1.55 (39)	0.26 (60)	4.75 (1,080)	1.2 (0.5)
		NPT Female	5.6 (144)	3.4 (87)	2.24 (57)	1.12 (28)	5.0 (127)	1.55 (39)	0.26 (60)	4.75 (1,080)	1.2 (0.5)
AF-3/4	3/4"	Sweat Female	5.6 (144)	3.4 (87)	2.24 (57)	1.12 (28)	6.3 (160)	1.55 (39)	0.45 (102)	8.50 (1,930)	1.5 (0.7)
		NPT Female	5.6 (144)	3.4 (87))	2.24 (57)	1.12 (28)	5.3 (135)	1.55 (39)	0.45 (102)	8.50 (1,930))	1.5 (0.7)
AF-1	1"	Sweat Female	6.8 (173)	4.3 (110)	2.54 (65)	1.27 (33)	7.6 (193)	2.00 (51)	0.60 (136)	10.56 (2,400)	3.1 (1.4)
		NPT Female	6.8 (173)	4.3 (110)	2.54 (65)	1.27 (33)	6.4 (163)	2.00 (51)	0.60 (136)	10.56 (2,400)	3.1 (1.4)
AF-1-1/4	1 1/4"	Sweat Female	7.0 (178)	4.3 (110)	2.54 (65)	1.27 (33)	7.9 (201)	2.00 (51)	0.88 (200)	22.01 (5,000)	3.6 (1.6)
		NPT Female	7.0 (178)	4.3 (110)	2.54 (65)	1.27 (33)	6.7 (170)	2.00 (51)	0.88 (200)	22.01 (5,000)	3.6 (1.6)
AF-1-1/2	1 1/2"	Sweat Female	7.9 (201)	5.1 (131)	3.60 (92)	1.8 (46)	10.6 (269)	2.52 (64)	3.17 (719)	32.58 (7,400)	7.6 (3.4)
		NPT Female	7.9 (201)	5.1 (131)	3.60 (92)	1.8(46)	9.2 (234)	2.52 (64)	3.17 (719)	32.58 (7,400)	7.6 (3.4)
AF-2	2"	Sweat Female	8.1 (207)	5.1 (131)	3.6 (92)	1.80 (46)	11.7 (297)	3.14 (80)	3.96 (900)	45.57 (10,350)	8.7 (3.9)
		NPT Female	8.1 (207)	5.1 (131)	3.6 (92)	1.80 (46)	9.7 (246)	3.14 (80)	3.96 (900)	45.57 (10,350)	8.7 (3.9)

*All dimensions +/- 0.125" (3.2 mm) tolerance. Dimensions are subject to change. Not to be used for construction purposes unless certified.

**Dimension is of maximum width of the handle or body, whichever is greater.

***Includes tailpiece. Measurement of maximum length tailpiece available.

For minimum differential requirements please refer to submittal A-611 on our website. Maximum differential pressure is 58 PSID.

Minimum temperature is 14°F (-10°C) to 248°F (120°C). Maximum operating pressure is 375 PSI.

NOTE: Model AF valves are configured valves and therefore have no part numbers. They include union tail pieces and can be selected to include optional ball isolation/shut-off valve.

VALVES Flo-Control™ Valves

Description

Flo-Control valves prevent gravity flow in forced hot water systems, and permit summer/winter operation of indirect water heaters.

Features

- Combination straight/angle configurations in sizes 3/4" to 2" for ease of installation.
- Removable cap allows easy cleaning and service without removing pipe connections.
- Manual operating position for vertical lift disc to permit gravity circulation.

Operating Data

Maximum Working Pressure: 125 PSIG (862 kPa)
Maximum Operating Temperature: 250°F (121°C)



Angle Pattern
2-1/2", 3"



Straight-Angle Pattern
3/4", 1", 1-1/4", 1-1/2", 2"



Bronze Straight Pattern
3/4"



Straight Pattern
2-1/2", 3", 4"

Specifications

Model Number	Part Number	Dimensions in Inches (mm)					Approx Shpg. Weight lbs. (kg)
		A	B	C	D	E	
SA 3/4	107034	3 1/8 (79)	4 15/16 (125)	1 5/8 (41)	1 9/16 (40)	1 7/16 (37)	2 (0.9)
SA 1	107018	3 1/2 (89)	5 1/2 (140)	1 7/8 (48)	1 3/4 (44)	1 1/2 (38)	3 (1.4)
SA 1 1/4	107019	4 (102)	6 1/2 (165)	2 1/4 (57)	1 31/32 (50)	1 7/8 (48)	4 (1.8)
SA 1 1/2	107020	5 (127)	7 1/4 (184)	3 (76)	2 1/2 (64)	2 1/4 (57)	8 (3.6)
SA 2	107021	6 7/8 (175)	7 1/2 (191)	4 5/8 (117)	4 (102)	2 5/8 (67)	12 (5.5)
A 2 1/2	107006	7 1/4 (184)	7 5/8 (194)	5 3/8 (137)	4 1/2 (114)	4 1/8 (105)	20 (9.1)
A 3	107007	7 1/2 (191)	7 3/4 (197)	6 (152)	4 1/2 (114)	4 1/4 (108)	23 (10.5)
S 2 1/2	107014	9 5/16 (237)	8 11/16 (221)	5 3/8 (137)	4 3/4 (121)	2 11/16 (68)	22 (10.0)
S 3	107015	9 15/16 (252)	9 (229)	6 (152)	5 1/4 (133)	3 (76)	24 (10.9)
S 4	107004	13 (330)	12 1/2 (318)	7 3/4 (197)	7 (178)	3 7/8 (98)	58 (26.4)
SB 3/4	107024	3 14/(83)	3 7/8 (98)	1 7/16 (37)	1 5/8 (41)	23/32 (18)	1.2 (0.6)

Dimensions are approximate and subject to change. Contact factory for certified dimensions.

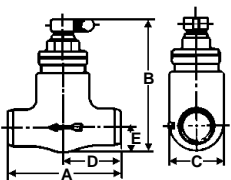

Sizes 3/4"
Bronze Straight Valve

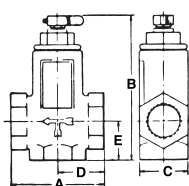

Sizes 3/4", 1", 1-1/4", 1-1/2"
Straight Angle Valves

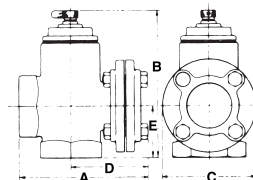

Sizes 2"
Straight Angle Valves

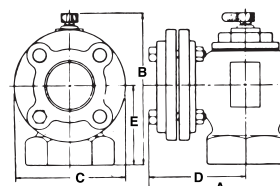

Sizes 2-1/2", 3"
Angle Valves

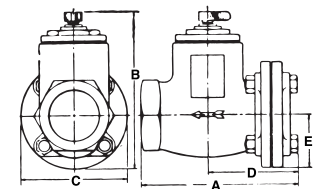

Sizes 2-1/2", 3", 4"
Straight Valves

VALVES Hydrotol™ Flow Control Valves

Description

The Hydrotol (HT) flow control valve is used to prevent overheating of zones due to gravity flow in hydronic heating systems and will permit summer-winter operation of indirect water heater. The HT valve allows fluid to pass when the system or zone pumps start. When the system or zone pumps are not operating, the HT valve remains closed, preventing gravity circulation. The HT valves are designed with a 1/2 turn knob that can be manually opened when draining the system or for bypass purposes. The HT valve can be installed in either the horizontal or vertical orientation.



Operating Data

Maximum Working Pressure: 150 PSI (10 bar)
 Maximum Operating Temperature: 250°F (121°C)

Materials of Construction

Body: Brass
 Internal Components: Non-Ferrous

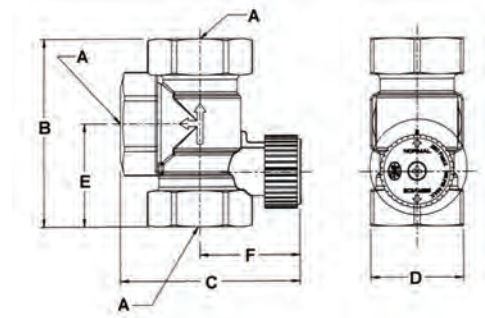

Specifications

Model Number	Part Number	Dimensions in Inches (mm)						Approx Shpg. Weight lbs. (kg)
		A	B	C	D	E	F	
HT-3/4	107035	3/4" NPTF	3 3/16 (82)	3 (76)	1 9/16 (40)	1 3/4 (44)	1 1/16 (43)	1.3 (0.6)
HT-1	107037	1" NPTF	3 5/8 (93)	3 3/16 (82)	1 9/16 (40)	1 15/16 (50)	1 1/16 (43)	1.2 (0.5)
HT-1 1/4	107038	1 1/4" NPTF	4 (101)	3 11/16 (93)	1 11/16 (43)	2 1/4 (57)	1 7/8 (48)	1.8 (0.8)

Do not use for construction. Dimensions are approximate and subject to change. Contact factory for certified dimensions.

VALVES DB-Differential Bypass Valve

Description

The differential bypass valve is used in systems where heating loads may be excluded from the circuit as zone valves close. It controls the excess flow in the system by acting as a bypass while ensuring adequate flow to the remaining open circuits. The differential bypass valve helps reduce velocity noise caused by excess flow through the circuits while maintaining the pump head at a constant value.

For hydronic systems utilizing zone valve

- Controls excess flow in the system when there is reduction in demand
- Available in 3/4" connection
- All brass body with non-ferrous internals

Operating Data

Maximum Working Pressure: 150 PSIG (1,034 kPa)
 Maximum Operating Temperature: 230°F (110 °C)
 Adjustment Range: 2 to 10 PSI

Materials of Construction

Valve Body: Brass
 Seals: EPDM
 Spring: Stainless Steel
 Knob: ABS

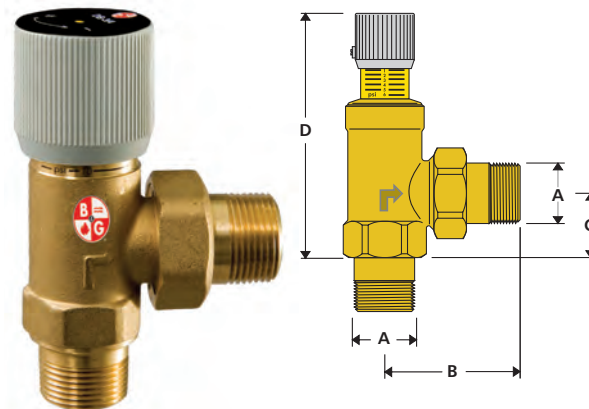

Specifications

Model Number	Part Number	A (mm)	B (mm)	C (mm)	D (mm)	Connection Type	Weight lbs. (kg)
DB-3/4	113247	3/4" (19)	2 5/16 (59)	1 (26)	4 (104)	M NPT	1 (0.45)

VALVES Pressure Reducing Valves

Description

Reducing valves fill the system to a preset pressure for optimum performance.

Features

- Fast fill feature reduces start-up time and labor.
- Low inlet pressure check valve helps prevent loss of system pressure if the supply water drops below system pressure.
- Convenient cleanable strainer is designed to prevent dirt and sediment from entering the system.
- Union connection available with 1/2" male NPT thread and 1/2" female sweat tail-piece for fast, flexible system connection.
- Lead-Free brass body construction is ideal for potable water systems.

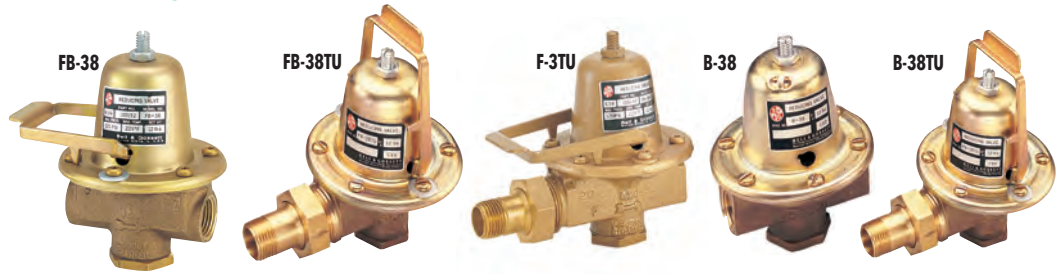

Specifications for Combination "Dual Units"

Model Number	Part Number	Component Valves	Body Material	Connection in Inches (mm)		Dimension in Inches (mm)		Approx. Shpg. Weight lbs. (kg)
				Boiler	Fill	Between Connections	Overall Height	
8	110199LF	Relief B-38	Lead-Free Brass	1/2 NPT	1/2 NPT	6 7/16 (164)	5 3/8 (137)	4 (1.8)
F-3	110197LF	Relief FB-38			1/2 NPT	6 7/16 (164)	6 (152)	3 3/4 (1.7)
F-3TU	110198LF	Relief FB-38TU			1/2 Union NPT/Sweat	8 5/8 (219)		4 (1.8)

Pressure settings: Relief 30 PSI Reducing 12 PSI standard; Field adjustable range: 10-25 PSI
Maximum operating temperature 225°F (107°C) - Maximum operating pressure 125 PSIG (862 kPa)

*CSA certified to NSF/ANSI 372 that product contains less than 0.25% lead content by weight on wetted surface.

Models ending in TU feature 1/2" sweat/NPT union connection.

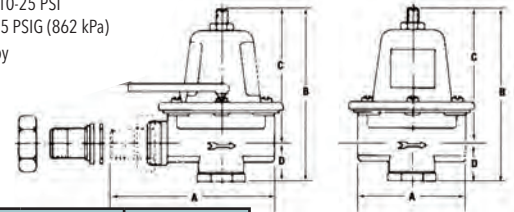

Specifications for Pressure Reducing Valve

Model Number	Part Number	Body Material	Connection Size - Inches	Factory Setting (PSIG)	Adjustable Range (PSIG)	Dimension in Inches (mm)				Approx. Shpg. Wt. lbs.(Kg)	
						A	B	C	D		
B-38	110190LF	Lead-Free Brass	1/2	12	10-25	3 1/16 (78)	4 13/16 (122)	3 11/16 (94)	1 1/8 (29)	1 3/4 (0.8)	
B7-12	110196LF		3/4			NPT	3 (76)	4 31/32 (126)	3 21/32 (93)	1 5/16 (33)	2 1/4 (1.0)
B-38TU	110191LF		1/2			Union*	4 31/32 (126)	4 13/16 (122)	3 11/16 (94)	1 1/8 (29)	2 (0.9)
FB-38	110192LF		1/2	NPT		3 1/16 (78)	1 3/4 (0.8)				
FB-38TU	110193LF		1/2	Union*		4 31/32 (126)	2 (0.9)				
6	110194LF		1/2	NPT		45	25-60	3 1/16 (78)	4 31/32 (126)	3 21/32 (93)	1 5/16 (33)
7	110195LF	3/4	NPT	45	25-60	3 (76)	4 31/32 (126)	3 21/32 (93)	1 5/16 (33)	2 1/4 (1.0)	

*Models ending in "TU" feature 1/2" sweat/NPT union connection.

ASME Safety Relief Valves

Description

ASME Safety Relief Valves protect fired and unfired hot water vessels against hazardous operating pressures.

Features

- Engineered in accordance with Section IV of the ASME boiler and pressure code for heating boilers with capacities certified by the National Board of Boiler and Pressure Vessel Inspectors.
- Offer the highest BTUH ratings available on the market today for valves in their class (790,000 to 5,999,000 BTUH)
- EPDM diaphragm operated (cast iron models) and diaphragm assisted (bronze models) have an effective area approximately 5 times greater than conventional "pop-type" relief valves to help overcome the effects of fouling.
- Low differential between opening and closing pressures helps to prevent conditions under which system water might flash to steam and cause hammering.



Nos. 3301 & 4100



Nos. 790 & 1170

Models 3301 & 4100 Iron Body Valves

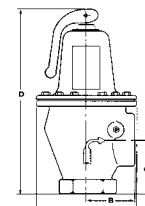

Models 790 & 1170 Bronze Body Valves

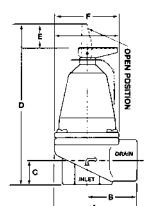

Size, Capacity & Relief Setting for B&G ASEME Safety Relief Valves*				
Relief Setting PSIG	Model Number Capacity in BTU Per Hour			
	Iron Body		Bronze Body	
30	3301-30	4100-30	790-30	1170-30
	3,300,000	4,100,000	790,000	1,170,000
36	3301-36	4100-36	790-36	1170-36
	3,800,000	4,600,000	900,000	1,330,000
45	3301-45	4100-45	790-45	1170-45
	4,500,000	5,515,000	1,065,000	1,575,000
50	3301-50	4100-50	790-50	1170-50
	4,900,000	5,990,000	1,160,000	1,710,000
75	Not Available		790-75	1170-75
			1,615,000	2,385,000
100	Not Available		790-100	1170-100
			2,075,000	3,060,000
125	Not Available		790-125	1170-125
			2,535,000	4,735,000

* Contact your local wholesaler or Bell & Gossett representative for availability of ASME Safety Relief Valves with special pressure settings and their part numbers.

Specifications

Model Number	Body	NPT Connections in inches		Dimension in Inches (mm)						Approx. Shpg. Wt. lbs.(Kg)
		Inlet	Outlet	A	B	C	D	E	F	
790	Bronze	3/4	3/4	2 9/16 (65)	1 1/2 (38)	3/4 (19)	4 9/16 (116)	1 1/32 (26)	2 3/32 (53)	1.2 (0.5)
1170		1	1	2 7/8 (73)	1 3/4 (44)	7/8 (22)	4 15/16 (125)		2 1/4 (57)	1.5 (0.7)
3301	Iron	1 1/2	2	6 (152)	2 7/8 (73)	3 1/4 (83)	11 (279)	N/A	N/A	17 (7.7)
4100		2								

Actual unit model numbers include individual valve pressure settings as a suffix to the basic valve model number noted.

Dimensions are approximate and subject to change. Contact factory for certified dimensions.

Maximum Operating Temperature: 250°F (121°C) - Maximum Working Pressure: Model 790 & 1170: 125 PSIG (862 KPa); Model 3301 & 4100: 50 PSIG (345 KPa).

ACCESSORIES Copper Red Ring Monoflo® Fittings

Description

Copper Red Ring Monoflo Fittings let you use a single pipe to serve as both supply and return main.

Features

- Connect risers to the main, assuring proper diversion of water to each heating unit regardless of type and its position in the system.
- Recommended for most installations including cast iron non-ferrous base boards, free-standing radiation or convectors.
- Only one fitting is needed for most installations for adequate diversion for upfeed radiation. For most applications, a second fitting can be used if higher resistance is required.

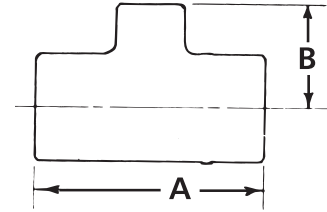

Operating Data

Maximum Working Pressure: 150 PSIG (1,034 kPa)
Maximum Operating Temperature: 300°F (149°C)

Specifications

Part Number	Size Inches	Dimensions in Inches (mm)*		Cv Ratings**		Approx. Shpg. Wt. lbs. (Kg)
		A	B	1 FTG	2 FTG	
108119	3/4 x 1/2***	2 7/32 (56)	1 (25)	4.2	—	1/4 (0.1)
108120	1 x 1/2	2 9/16 (65)	1 5/32 (30)	14.5	8.7	1/2 (0.2)
108121	1 x 3/4	2 3/4 (70)	1 3/8 (35)			
108122	1 1/4 x 1/2	2 3/4 (70)	1 7/32 (31)	24.0	15.5	
108123	1 1/4 x 3/4	2 27/32 (72)	1 3/8 (35)	39.0	25.0	1-1/4 (0.6)
108124	1 1/2 x 3/4	3 3/32 (78)	1 11/16 (42)			
108125	1 1/2 x 1	3 3/8 (86)	1 11/16 (42)	80.0	55.0	1-3/4 (0.8)
108126	2 x 3/4	3 1/2 (89)	1 27/32 (47)			
108127	2 x 1	3 13/16 (97)	2 1/32 (52)			

* Do not use for construction. Dimensions are approximate and subject to change. Contact factory for certified dimensions.

** With Side Branch plugged.

*** Return only.

AIR SEPARATORS Inline Air Separator

Description

The B&G In-Line Air Separator is specifically designed to efficiently separate air from circulating water in hydronic heating and cooling systems to assure a quiet operation.

Operating Data

Maximum Working Pressure: 175 PSIG (1,207 kPa)
Maximum Operating Temperature: 300°F (149°C)

Materials of Construction

One Piece Cast Iron

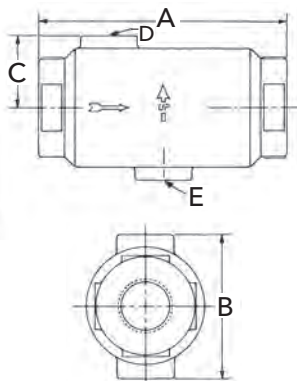

Specifications

Model Number	Part Number	Size NPT	Max Flow (GPM)	Dimension in Inches (mm)					Approx. Shpg. Wt. lbs.
				A	B	C	D	E	
IAS - 1	112118	1"	15	6 1/8	3 1/2 (89)	1 3/4 (45)	1/8 NPT	1/2 NPT	3 3/4
IAS - 1 1/4	112119	1 1/4"	25	(156)					3 1/2
IAS - 1 1/2	112097	1 1/2"	35	8 1/8	4 1/2	2 1/4 (57)	8 1/2		
IAS - 2	112098	2"	50	(207)	(114)	3/4 NPT	3 3/16 (81)	1/2 NPT	7 1/2
IAS - 2 1/2	112099	2 1/2"	75	10 1/8	6-3/8				23
IAS - 3	112100	3"	125	(257)	(257)	21 1/2			

Dimensions are approximate and subject to change. Contact factory for certified dimensions.

AIR SEPARATORS EASB-Jr Enhanced Air Separator

Description

Bell & Gossett's Model EASB-JR Enhanced Air Separator automatically removes entrained air bubbles in hydronic systems. As fluid enters the EASB-JR, the velocity is decreased creating a low pressure area. The small bubbles are released from fluid and then collected on the coalescing medium. As the bubbles coalesce, they rise to the top of the air separator where they are released to atmosphere through the built-in automatic air vent. The air separator has a bottom 1/2" NPT connection to accommodate a B&G diaphragm expansion tank. The compact design and brass body construction make the EASB-JR ideal for residential and commercial hydronic heating systems.

Operating Data

Maximum Working Pressure: 150 PSI (10 bar)
Maximum Operating Temperature: 250°F (121°C)

Materials of Construction

Body & Cap: Brass
Coalescing Medium: Stainless Steel
Venting Mechanism: Non-Ferrous

Specifications

Model Number	Part Number	Size	Dimension in Inches (mm)						Approx. Shpg. Wt. lbs.
			A	B	C	D	E	F	
EASB-3/4 JR	112111	3/4" NPT	6 7/8 (175)	1 5/8 (41)	1 13/16 (46)	3 5/8 (92)	2 1/4 (57)	3/4" NPTF	2.5 (1)
EASB-3/4S JR	112114	3/4" Sweat	6 7/8 (175)	1 5/8 (41)	1 13/16 (46)	3 5/8 (92)	2 1/4 (57)	3/4" Sweat	2.5 (1)
EASB-1 JR	112112	1" NPT	6 7/8 (175)	1 5/8 (41)	1 13/16 (46)	3 5/8 (92)	2 1/4 (57)	1" NPTF	2.5 (1)
EASB-1S JR	112115	1" Sweat	6 7/8 (175)	1 5/8 (41)	1 13/16 (46)	3 5/8 (92)	2 1/4 (57)	1" Sweat	2.5 (1)
EASB-1 1/4 JR	112113	1 1/4" NPT	7 1/2 (191)	1 7/8 (48)	2 5/16 (59)	4 5/8 (117)	3 1/8 (79)	1 1/4" NPTF	4 (1.8)
EASB-1 1/4S JR	112116	1 1/4" Sweat	7 1/2 (191)	1 7/8 (48)	2 5/16 (59)	4 5/8 (117)	3 1/8 (79)	1 1/4" Sweat	4 (1.8)
EASB-1 1/2 JR	112117	1 1/2" NPT	7 1/2 (191)	1 7/8 (48)	2 5/16 (59)	4 5/8 (117)	3 1/8 (79)	1 1/2" NPTF	4 (1.8)
EASB-2 JR	112464	2" NPT	7 1/2 (191)	2 (51)	2 1/2 (64)	5 (127)	3 1/8 (79)	2" NPTF	5 (2.3)

Dimensions are approximate and subject to change. Contact factory for certified dimensions.



Dimensions & Weights

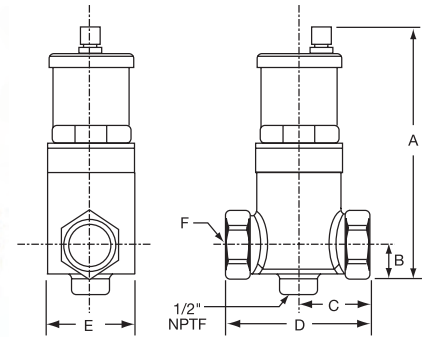

Enhanced Air Separator

Description

Bell & Gossett's Model EAS Enhanced Air Separator is a patented, innovative design in air separators. It has been engineered to remove entrained air from hydronic heating and cooling systems providing far superior air removal compared with other devices available today. The EAS is ideal for residential, institutional and light commercial applications.

Specifications

Model Number	Part Number	Max. Flow (GPM)	Size Inches NPT	Dimension in Inches (mm)					Approx. Shpg. Wt. lbs.
				A	B	C	D	E	
EAS-1	112105	35	1	12 3/16 (310)	6 7/8 (175)	6 7/16 (164)	3 15/16 (100)	3 (76)	8.8 (4)
EAS-1	112106	35	1 1/4	12 3/16 (310)	6 7/8 (175)	6 7/16 (164)	3 15/16 (100)	3 (76)	8.4 (3.8)
EAS-1	112107	45	1 1/2	15 3/4 (400)	11 3/8 (289)	8 5/8 (219)	4 7/8 (124)	4 1/4 (108)	15.5 (7)
EAS-2	112108	70	2	17 1/2 (445)	11 3/8 (289)	8 5/8 (219)	4 7/8 (124)	4 1/4 (108)	15.25 (6.9)

EAS-1 or EAS- 1 1/4 Max. Width 4 1/16" (103mm)

EAS- 1 1/2 or EAS-2 Max. Width 5 3/4" (146mm)

Operating Data

Maximum Working Pressure: 150 PSI (10.3 bar)
Maximum Operating Temperature: 250°F (121°C)

Materials of Construction

Body & Cap: Cast Iron
Internals: Stainless Steel
3/4" Large Capacity Air Vent: Brass Body Nonferrous Internals

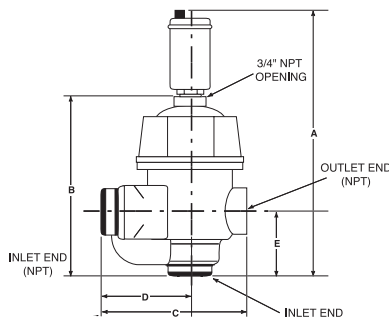

How It Works

- As system fluid enters through the inlet, (either straight or angle) the diffuser distributes flow evenly across the stainless steel, wire brush-like medium.
- Air bubbles, even micro air bubbles, stick to the brush filaments.
- Trapped air rises above the diffuser through a baffle (not pictured), where the air is then released through an opening on top.
- Deaerated water then goes back into the system.

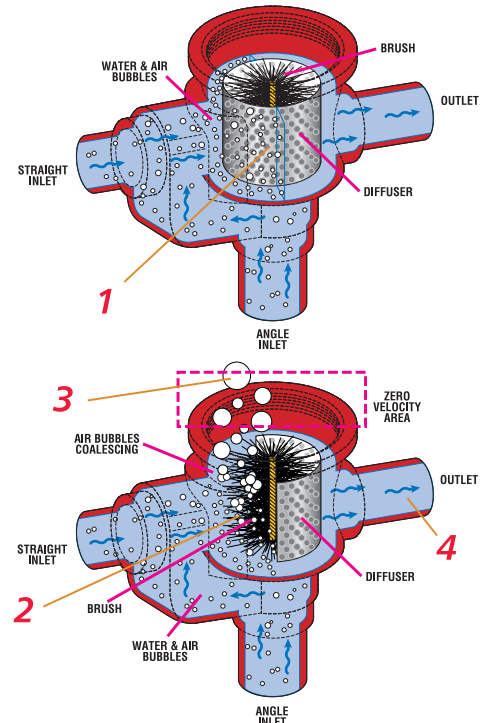

HYDRONIC SPECIALTIES

RV-125A Readout Valve and RP-250B Readout Probe

The RV-125A is designed for use wherever pressure tappings are required to monitor flow or pressures. The Readout Valve is fitted with an EPT insert which incorporates a unique check valve feature designed to check flow when the Readout Valve is not being used to monitor flow. Use companion RP-250B Readout Probes with the RV-125A Readout Valve. **300 PSIG Working Pressure – 250°F Maximum Operating Temperature**



TB- Thermoflo® Balancer

A device for instant visual balancing of hot or cold water flows. With a B&G Thermoflo balancer installed in each circuit or zone, the entire system can be quickly balanced to meet original design calculation. No. TB-3/4"- Capacity 1 to 5 GPM. No. TB-1"- Capacity 2 to 10 GPM. **125 PSIG Working Pressure – 250°F Maximum Operating Temperature**



DT-2 Drain-O-Tank® Air Charger

The Drain-O-Tank Air Charger offers a sure, quick way to recharge a water-logged compression tank. **125 PSIG Working Pressure – 240°F Maximum Operating Temperature**



AIR VENTS

Model No. 107A High Capacity Air Vent

A rugged High Capacity Air Vent designed to purge free air from liquid systems at **operating pressures up to 150 PSIG**. The Model 107A Air Vent has a cast iron body and bonnet, with stainless steel, brass and EPDM internal components and is suitable for a **maximum operating temperature of 250°F**. The Air Vent has a 3/4" NPT inlet and 3/8" NPT outlet.



No. 97 Automatic Air Vent

A float type vent designed to vent troublesome air from hydronic heating systems. The brass body and the non-ferrous internals provide years of reliable service. The compact design (3-1/8" x 1-7/8") and high operating pressure/temperature (**240°F @ 150 PSIG**) limitations make the No. 97 a must in any hydronic heating system.



No. 26 Vacuum Breaker

Designed to protect closed vessels and piping systems against collapse when the induced vacuum exceeds design conditions. When used on steam heating systems, the No. 26 Vacuum Breaker controls induced vacuum, permitting normal return of condensate to the boiler. Adjustable range 1/4" to 20" (mercury) vacuum. Factory set to 4" – **240 PSIG Maximum Working Pressure – 300°F Maximum Operating Temperature**



No. 98

A high capacity automatic air vent that is designed to remove air in closed loop systems. Materials of construction: Brass body with non-ferrous internals. **Maximum Working Pressure: 150 PSI. Maximum Operating Temperature: 250°F**



No. 87, 67 and 7 Automatic Air Vents

Designed to vent the accumulation of troublesome air wherever it can be trapped. These non-ferrous automatic air vents are 4-3/4" x 2-1/4", 3-3/16" x 1-1/2" and 4-1/16" x 2-3/16" (height and width), respectively, and are rated for a **maximum operating temperature of 240°F at pressures of 150, 35 and 75 PSI, respectively**. The No. 87 has a combination of 1/2" FPT/3/4" MPT connection, whereas No.'s. 67 and 7 have 1/8" MPT, and FPT connections.



No. 4V "Coin-Operated" Air Vent

Specially designed for the new types of radiators. An important feature is that it projects only slightly, being almost flush with the radiator. **150 PSIG Working Pressure – 250°F Maximum Operating Temperature**



Specifications

Model Number	Part Number	Description	System Connection	Dimension (W x H)	Maximum		Approx. Shpg. Wt. lbs. Carton of	
					Pressure	Temperature		
98	113246	Automatic Air Vent	1/2" NPTF	4 1/2" x 9 5/8"	150 PSIG	250°F	1	.8
97	113222		1/8" NPTM	1 7/8" x 3 1/8"			1	.8
87	113021		Combination 3/4" NPTM 1/2" NPTF	2 1/4" x 4 3/4"			1	.61
67	113020		1/8" NPTM	1 1/2" x 3 3/16"	35 PSIG	.25		
7	113001		1/8" NPTF	2 3/16" x 4 1/16"	75 PSIG	.5		
107A	113076	High Capacity Air Vent	3/4" NPTF	4 1/2" x 9 5/8"	150 PSIG	250°F	1	10
4V	113055	Manual Air Vent	1/8" NPTM	5/8" x 5/8"	150 PSIG	250°F	48	2
26	113075	Vacuum Breaker	3/4" NPTM	1 1/4" x 3"	240 PSIG	300°F	6	3
RV-125A	113100	Readout Valve	1/8" NPTM	1 1/8" x 9/16"	300 PSIG	250°F	50 pairs	4
1/4" P/T	V58050PK	Readout Valve	1/4" NPTM	1 1/4" x 1 1/4"	300 PSIG	250°F	1	.1
1/8" P/T	G97030	Readout Valve	1/8" NPTM	1 1/8" x 1 1/4"	300 PSIG	240°F	1	.5
RP-250B	113102	Readout Probe	N/A	2" x 5/8"	300 PSIG	250°F	6 pairs	1
DT-2	113041	Drain-O-Tank	1/2" NPTM	2 1/4" x 6 5/16"	125 PSIG	240°F	1	.67
TB-3/4	127001	Balance Valve	3/4" NPTF	2" x 9 1/4"	125 PSIG	250°F	6	26
TB-1	127002	Balance Valve	1" NPTF	2" x 9 1/4"	125 PSIG	250°F	6	26

ACCESSORIES PSH - Primary/Secondary Header

Description

The B&G low-loss header, Model PSH, is a combination air separator and manifold that creates independent primary and secondary circuits. The B&G Model PSH is equipped with a purge valve allowing the user to remove any debris deposited on the bottom of the vessel and an air vent releasing trapped air in the system. The insulation, which is provided as standard, prevents water vapors entering from the outside and eliminates the formation of condensate on the PSH body.

Operating Data

With Insulation:

Working Pressure: 150 PSI
 Operating Temperature Threaded: 32°- 210°F
 Operating Temperature Flanged: 32°- 220°F

Without Insulation:

Working Pressure: 150 PSI
 Operating Temperature Threaded & Flanged: 32°-230°F

Materials of Construction

Body: Steel
 Air Vent: Brass
 Drain Valve: Brass
 Insulation-Threaded: PEX
 Insulation-Flanged: Polyurethane Foam

Connection

1", 1-1/4" and 1-1/2" Female NPT
 2", 2-1/2", 3" and 4" ANSI 150 CLASS Flange

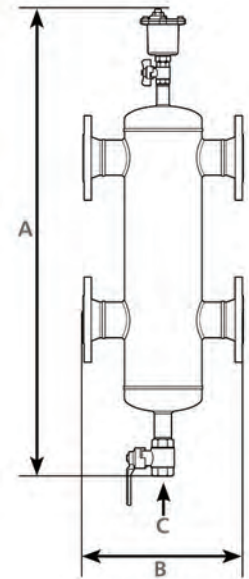
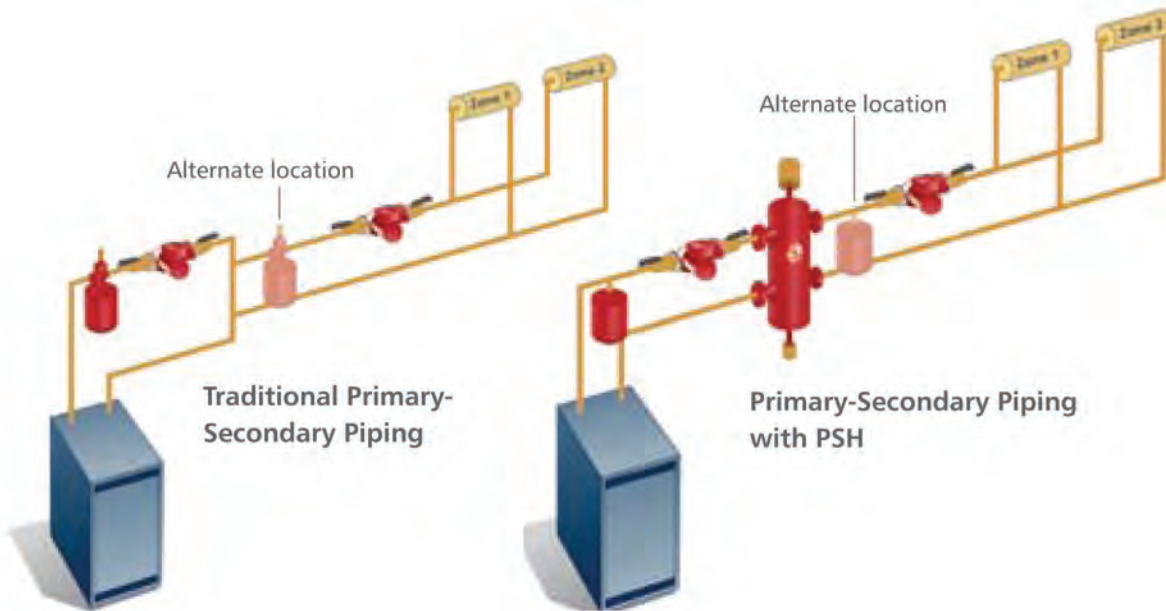

Specifications

Model Number	Part Number	Connection Size Inches (mm)	Max Flow GPM (m3/h)	A Inches (mm)	B Inches (mm)	C Drain Connection Size Inches (mm) NPT	Weight lbs. (Kg)
PSH-1	112465	1 (25.4)	11 (2.5)	24-3/8 (619)	8-7/8 (225)	1/2 (12.7)	6.0 (2.7)
PSH-1.25	112466	1-1/4 (31.75)	18 (4)	26-3/4 (679)	9-3/4 (248)	1/2 (12.7)	8.3 (3.8)
PSH-1.5	112467	1-1/2 (38.1)	26 (6)	28-1/3 (719)	11-1/8 (282)	1/2 (12.7)	12.6 (5.7)
PSH-2	112468	2 (50.8)	40 (9)	42 (1069)	13-13/16 (350)	1-1/4(31.7)	78.7 (35.7)
PSH-2.5	112469	2-1/2 (63.5)	80 (18)	42 (1069)	13-13/16 (350)	1-1/4(31.7)	87.7 (39.8)
PSH-3	112470	3 (76.2)	124 (28)	50-3/8 (1279)	18-3/8 (466)	1-1/4(31.7)	108.0 (49)
PSH-4	112471	4 (101.6)	247 (56)	50-3/8 (1279)	18-1/2 (470)	1-1/4(31.7)	116.8 (53)

TANKS HFT Diaphragm Tanks • Expansion Tanks for Hydronic Heating

Description

Bell & Gossett HFT expansion tanks are designed to absorb the force of thermal expansion in hydronic heating systems. Series HFT tanks for hydronic heating systems are available in sizes from 2–86 gallons. The Series HFT tank is designed to absorb the force of thermal expansion of heating water to maintain proper pressurization in a closed hydronic system. The heavy duty butyl diaphragm separates system water from the air in the tank preventing water logging problems.



HFT-15 thru HFT-90

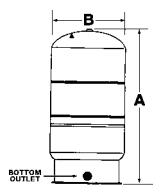

HFT-30V thru HFT-160V

Specifications

Model Number	Part Number	Volume Gallons (Liters)		Height (A) Inches (mm)	Diameter (B) Inches (mm)	System Connection	Approx. Shpg. Wt. lbs. (Kg)
		Tank	Acceptance				
HFT-15	1BN326	2 (7.5)	1.0 (3.7)	12 5/8 (321)	8 (203)	1/2" NPTM	5 (2.3)
HFT-30	1BN327	4.4 (16.6)	2.5 (9.4)	14 (355)	11 (279)		9 (4.1)
HFT-60	1BN328	7.6 (28.7)	2.5 (9.4)	17 1/4 (438)	11 (279)		14 (6.4)
HFT-90	1BN329	14 (53)	11.3 (42.8)	21 (533)	15 5/8 (390)	1" NPTF	23 (10.4)
HFT-30V	1BN330	14 (53)	11.3 (42.8)	24 3/4 (639)	15 5/8 (390)		24 (11)
HFT-40V	1BN331	20 (75.7)	11.3 (42.8)	32 1/2 (826)	15 5/8 (390)		34 (15.5)
HFT-60V	1BN332	32 (121.1)	11.3 (42.8)	47 1/2 (1207)	15 5/8 (390)		52 (23.6)
HFT-90V	1BN333	44 (166.5)	34 (128.7)	36 1/2 (927)	22 (559)	1 1/4" NPTF	64 (29)
HFT-110V	1BN334	62 (234.6)	34 (128.7)	48 1/2 (1232)	22 (559)		89 (40.5)
HFT-160V	1BN335	86 (325.5)	46 (174.1)	46 (1168)	22 (559)		116 (53)

Operating Data

Maximum Working Pressure: 100 PSI (689 kPa)
 Maximum Operating Temperature: 240°F (115°C)
 Standard Factory Pre-charge: 12 PSI (83 kPa)

Materials of Construction

Shell: Carbon Steel
 Diaphragm: Heavy Duty Butyl Rubber
 Connection: Steel



Compression Tanks

Air-tight, ASME constructed. Available in painted steel. Sizes 15 to 505 gallons. Gauge glass tapplings are standard. Always use with B&G Airtrol Tank Fittings.



Specifications

Model Number	Part Number	Capacity Gallons	Required Airtrol Fitting	Tank Dia. Inches	Tank Length Inches	Approx. Shpg. Wt. lbs.
15	116661	15	ATF-12	12	33	44
24	116662	24		12	51	62
30	116663	30		14	48	72
40	116664	40	ATF-16	14	63	92
60	116665	60		16	72	120
80	116666	80	ATF-20	20	62	136
100	116667	100		20	78	168
120	116668	120	ATF-24	24	65	218
135	116669	135		24	72	238
175	116670	175	ATFL	30	62	338
220	116671	220		30	77	368
240	116672	240		30	84	394
305	116673	305		30	105-3/4	486
400	116674	400		36	92-1/2	645
505	116675	505		36	120	810

Sizing Guideline

Boiler Size	Type of Radiation			
	Finned Tube Baseboard or Radiant Panel	Convectors or Unit Heaters	Radiators Cast Iron	Baseboard Cast Iron
Net Output	Use Tank Model			
BTU/HR	HFT-15	HFT-15	HFT-15	HFT-15
25,000	HFT-15	HFT-15	HFT-30	HFT-30
50,000	HFT-30	HFT-30	HFT-30	HFT-60
75,000	HFT-30	HFT-60	HFT-60	HFT-60
100,000	HFT-30	HFT-60	HFT-60	HFT-90
125,000	HFT-30	HFT-60	HFT-90	HFT-90
150,000	HFT-60	HFT-60	HFT-30V	HFT-30V
200,000	HFT-60	HFT-90	HFT-30V	HFT-40V
250,000	HFT-90	HFT-30V	HFT-30V	HFT-40V
300,000	HFT-30V	HFT-30V	HFT-40V	HFT-60V
350,000	HFT-30V	HFT-40V	HFT-40V	HFT-60V
400,000	HFT-30V	HFT-40V	HFT-40V	HFT-60V

Assumptions: fill pressure 12 PSI, relief pressure 30 PSI, average system temperature 200 °F, system fluid is water, consult factory with requirements not shown.

Airtrol® Tank Fittings

Directs free air to the compression tank. Restricts thermal circulation to boiler. Establishes initial tank air level. Allows compression tank size reduction.

ATFL



ATF



Specifications

Model Number	Part Number	Tank Dia. Inches (mm)	Connection (NPT)		Approx. Shpg. Wt. lbs. (Kg)
			Tank	Boiler	
ATF-9	112008	9 (228.6)	1/2" M	3/4" M	2.25 (1.0)
ATF-12	112010	12-14 (304-355)			2.5 (1.4)
ATF-16	112011	16-18 (152-357)			2.75 (1.3)
ATF-20	112026	20-22 (508-558)			
ATF-24	112013	24 (609)			
ATFL*	112014	>100 gal	1" F	1" F	14 (6.4)

* DT-2 Drain-O-Tank Air Charger comes with ATFL model

TANKS PTA Diaphragm Tanks Expansion Tanks for Potable Water Systems

Description

Bell & Gossett PTA expansion tanks are designed to absorb the force of thermal expansion in domestic potable water systems. Tanks for potable water systems, Series PTA (ASME construction) are available in sizes from 2–528 gallons.

Residential/Light Commercial ASME Diaphragm Tanks

Operating Data

Maximum Working Pressure:
PTA-5 thru PTA-210V: 150 PSI (1,035 kPa)
Maximum Operating Temperature: 240°F (115°C)

Materials of Construction

Shell: Carbon Steel
Liner: Polypropylene
Diaphragm: Heavy Duty Butyl Rubber
System Connection: PT-25V thru PT-210V are stainless steel. All others are brass
Factory Pre-charge: 40 PSI (276 kPa)

Commercial ASME Bladder Tanks

Maximum Working Pressure: 150 PSI (1035 kPa)
Maximum Operating Temperature: 240°F (116°C)

Materials of Construction

Shell: Carbon Steel
Liner: Polypropylene
Diaphragm: Heavy Duty Butyl Rubber
System Connection: Bronze
Factory Pre-charge: 55 PSI (379 kPa)

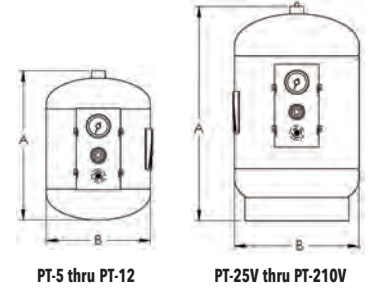

PT-5 thru PT-12

PT-25V thru PT-210V

Specifications

Model Number	Part Number	Volume Gallons (Liters)		Height (A) Inches (mm)	Diameter (B) Inches (mm)	System Connection	Approx. Shpg. Wt. lbs. (Kg)
		Tank	Acceptance				
PTA-5	1BN346LF	3.5 (13)	2.3 (9)	14 (356)	10 (254)	3/4" NPTM	22 (10)
PTA-12	1BN347LF	5 (19)	3.3 (12)	14 (356)	12 (305)		28 (13)
PTA-20V	1BN348LF	8 (30)	5.3 (20)	21 (508)			34 (15)
PTA-30V	1BN349LF	15 (57)	10 (38)	25 (610)	16 (406)	1" NPTF	50 (23)
PTA-42V	1BN350LF	22 (83)	14 (53)	31 (787)			57 (26)
PTA-60V	1BN351LF	26 (98)	18 (68)	34 (864)			62 (28)
PTA-80V	1BN352LF	35 (132)	24 (91)	45 (1,143)			80 (36)
PTA-100V	1BN353LF	45 (170)	30 (113)	39 (991)	20 (508)		110 (50)
PTA-125V	1BN354LF	60 (227)	40 (151)	50 (1,270)			134 (61)
PTA-160V	1BN355LF	70 (265)	47 (178)	47 (1,194)	24 (610)	1-1/2" NPTF	177 (80)
PTA-180V	1BN356LF	80 (302)	53 (200)	50 (1,270)			184 (83)
PTA-210V	1BN357LF	90 (340)	60 (227)	53 (1,346)			193 (88)

Larger sizes are available.

Code approvals: PT-5, PT-12



PT-25V thru PT-210



TANKS Series WTA Hydro-Pneumatic for Potable Well Water Systems

Description

The Series WTA tank will help protect the pump and pressure switches against short cycling. The domestic well tank delivers adequate water under pressure between pump cycles to meet the required demand.

Specifications

Model Number	Part Number	Volume (Gallons)		Dimensions (Inches)					System Connection	Shipping Weight LBS (Kg)
		Tank	Acceptance	A	B	C	D	E		
WTA-401	1BN151LF	18	11	31-1/4	16-1/4	1-1/2	N/A	N/A	1" NPTF	95 (43)
WTA-402	1BN152LF	25		39-3/4						112 (51)
WTA-403	1BN153LF	34		49-1/4						123 (56)
WTA-404	1BN154LF	68	34	47-1/4	24	1-5/8	N/A	1-1/4" NPTF	210 (95)	
WTA-405	1BN155LF	90		59-1/4					280 (127)	
WTA-447	1BN156LF	53	53	45-1/4	2	3-3/4	19	2" NPTF	263 (120)	
WTA-448	1BN157LF	80	80	59-1/8					308 (140)	
WTA-449	1BN158LF	106	106	73-1/8					352 (160)	
WTA-450	1BN159LF	132	132	86-5/8					392 (178)	
WTA-451	1BN160LF	158	158	73-1/4	30	3-1/2	5-1/2	24	513 (233)	
WTA-452	1BN161LF	211	211	91					760 (345)	
WTA-453	1BN162LF	264	264	86	36	4-1/2	7	30	810 (367)	
WTA-454	1BN163LF	317	317	98					914 (415)	
WTA-455	1BN164LF	370	370	110-3/8					1,018 (462)	
WTA-456	1BN165LF	422	422	81-7/8	48	7-1/8	7-1/8	42	1,655 (50)	
WTA-457	1BN166LF	528	528	97-1/4					1,925 (873)	

Operating Data

Maximum Design Pressure:
WTA-401 thru WTA-457: 125 PSI (1,034 kPa)
Maximum Design Temperature:
WTA-401–WTA-405: 200°F (93°C)
WTA-447–WTA-457: 240°F (116°C)

Materials of Construction

Shell: Steel
System Connection: Malleable Iron
WT-401–WT-405: Butyl Diaphragm, Polypropylene Liner
WT-421–WT-457: Butyl Bladder
Factory Pre-charged:
WTA-401 thru WTA-405: 30 PSI (207 kPa)
WTA-447 thru WTA-457: 25 PSI (172 kPa)

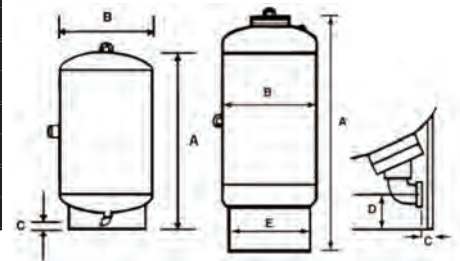

Models WTA-401 through WTA-405

Models WTA-447 through WTA-457

VALVES TPV - Tank Purge Valves

Description

Combination full port shut-off valve and drain valve used to connect an expansion tank to the system. It is important that the pre-charge in an expansion tank be maintained at the proper pressure at all times. This pressure is the lowest system operating pressure. When the tank's pressure is adjusted, there should be no system liquid in it. This pre-charge should be checked and adjusted when:

- Tank is first installed
- If system is started or operating with the incorrect tank pre-charge
- Annually to assure proper pre-charge pressure at all times

The TPV (Tank Purge Valve) is ideal for this as the tank can be isolated from the system, drained and the pre-charge checked and adjusted without draining or shutting down the system.

The TPV also serves as a service valve should the tank need to be removed or have the bladder changed. These valves are furnished standard with a drain valve with a standard 5/8" hose connection.

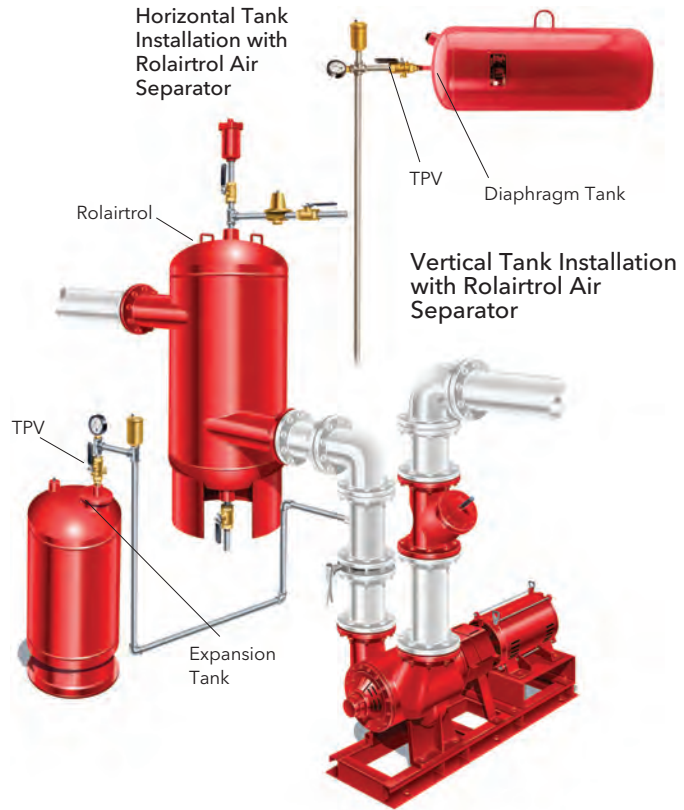

Operating Data

Maximum Working Pressure:

400 PSIG (2,758 kPa)

Maximum Operating Temperature:

-4°F (-20°C) to 250°F (121°C)

Materials of Construction

Valve Body: Brass

Ball: Chrome Plated

Ball Seal: PTFE

Stem: Explosion Proof

O-Ring: EPDM

Specifications

Model Number	Part Number	System Connection	Tank Connection	Dimensions* Inch (mm)									Approx. Weight Lbs.
				A	B	C	D	E	F	G	H	J	
TPV-1/2SF	113226	1/2" Female SWT	1/2" Female NPT	1.67 (42.4)	2.25 (57.2)	3.15 (80.0)	3.82 (97.0)	0.84 (21.3)	1.60 (40.6)	2.36 (59.9)	1.75 (44.5)	3.34 (84.8)	1.0 (0.5)
TPV-1/2FF	113227	1/2" Female NPT	1/2" Female NPT	1.19 (30.2)	2.00 (50.8)	2.90 (73.7)	3.55 (90.4)	0.84 (21.3)	1.60 (40.6)	2.36 (59.9)	1.75 (44.5)	3.34 (84.8)	1.0 (0.5)
TPV-1/2SM	113228	1/2" Female SWT	1/2" Male NPT	1.29 (32.2)	2.25 (57.2)	3.15 (80.0)	4.73 (120.1)	0.84 (21.3)	1.60 (40.6)	2.36 (59.9)	1.75 (44.5)	3.34 (84.8)	1.0 (0.5)
TPV-1/2FM	113229	1/2" Female NPT	1/2" Male NPT	1.06 (26.9)	2.00 (50.6)	2.90 (73.7)	4.47 (113.6)	0.84 (21.3)	1.60 (40.6)	2.36 (59.9)	1.75 (44.5)	3.34 (84.8)	1.0 (0.5)
TPV-3/4SF	113230	3/4" Female SWT	3/4" Female NPT	1.67 (42.2)	2.85 (72.4)	3.72 (94.5)	4.53 (115.1)	1.06 (26.9)	1.95 (49.5)	2.66 (67.6)	1.89 (48.0)	3.50 (88.9)	1.24 (0.6)
TPV-3/4FF	113231	3/4" Female NPT	3/4" Female NPT	1.19 (30.2)	2.50 (63.5)	3.26 (82.8)	4.06 (103.1)	1.06 (26.9)	1.95 (49.5)	2.66 (67.6)	1.69 (48.0)	3.50 (88.9)	1.24 (0.6)
TPV-3/4SM	113232	3/4" Female SWT	3/4" Male NPT	1.67 (42.2)	2.85 (72.4)	3.72 (94.5)	5.50 (140.0)	1.06 (26.9)	1.95 (49.5)	2.66 (67.6)	1.69 (48.0)	3.50 (88.9)	1.25 (0.6)
TPV-3/4FM	113233	3/4" Female NPT	3/4" Male NPT	1.19 (30.2)	2.50 (63.5)	3.26 (82.8)	5.03 (127.6)	1.06 (26.9)	1.95 (49.5)	2.66 (67.6)	1.69 (48.0)	3.50 (88.9)	1.25 (0.6)
TPV-1SF	113234	1" Female SWT	1" Female NPT	1.95 (49.5)	3.18 (80.6)	4.14 (105.2)	5.05 (126.3)	1.23 (31.2)	2.06 (52.3)	2.71 (68.6)	2.00 (50.8)	4.00 (101.6)	1.71 (0.8)
TPV-1FF	113235	1" Female NPT	1" Female NPT	1.46 (36.8)	2.63 (66.5)	3.60 (91.4)	4.50 (114.3)	1.23 (31.2)	2.06 (52.3)	2.71 (68.6)	2.00 (50.8)	4.00 (101.6)	1.71 (0.8)
TPV-1SM	113236	1" Female SWT	1" Male NPT	1.95 (49.5)	3.18 (80.6)	4.14 (105.2)	6.16 (156.5)	1.23 (31.2)	2.06 (52.3)	2.71 (68.6)	2.00 (50.8)	4.00 (101.6)	1.75 (0.8)
TPV-1FM	113237	1" Female NPT	1" Male NPT	1.45 (36.8)	2.53 (60.8)	3.60 (91.4)	5.60 (142.2)	1.23 (31.2)	2.06 (52.3)	2.71 (68.6)	2.00 (50.8)	4.00 (101.6)	1.75 (0.8)
TPV-1 1/4SF	113238	1 1/4" Female SWT	1 1/4" Female NPT	2.13 (54.1)	3.94 (100.1)	5.14 (130.6)	6.10 (154.9)	1.34 (34.0)	2.71 (68.8)	2.96 (75.2)	2.45 (62.2)	4.50 (114.3)	3.15 (1.5)
TPV-1 1/4FF	113239	1 1/4" Female NPT	1 1/4" Female NPT	1.55 (39.4)	3.37 (85.6)	4.56 (115.6)	5.50 (139.7)	1.34 (34.0)	2.71 (68.8)	2.96 (75.2)	2.45 (62.2)	4.50 (114.3)	3.15 (1.5)
TPV-1 1/4SM	113240	1 1/4" Female SWT	1 1/4" Male NPT	2.13 (54.1)	3.94 (100.1)	5.14 (130.6)	7.11 (180.6)	1.34 (34.0)	2.71 (68.8)	2.96 (75.2)	2.45 (62.2)	4.50 (114.3)	3.19 (1.5)
TPV-1 1/4FM	113241	1 1/4" Female NPT	1 1/4" Male NPT	1.55 (39.4)	3.37 (85.6)	4.56 (115.6)	6.52 (165.6)	1.34 (34.0)	2.71 (68.8)	2.96 (75.2)	2.45 (62.2)	4.50 (114.3)	3.19 (1.5)
TPV-1 1/2SM	113242	1 1/2" Female SWT	1 1/2" Male NPT	2.54 (64.5)	4.66 (118.4)	5.90 (149.9)	8.32 (211.3)	1.85 (47.0)	3.25 (82.6)	3.38 (85.9)	3.00 (76.2)	5.30 (134.5)	5.50 (2.5)
TPV-1 1/2FM	113243	1 1/2" Female NPT	1 1/2" Male NPT	1.91 (48.5)	3.97 (100.8)	5.12 (130.1)	7.64 (194.1)	1.85 (47.0)	3.25 (82.6)	3.38 (85.9)	3.00 (76.2)	5.30 (134.5)	5.50 (2.5)
TPV-2SM	113244	2" Female SWT	2" Male NPT	2.89 (72.4)	4.57 (116.1)	6.80 (172.7)	9.80 (248.9)	2.00 (50.8)	4.00 (101.6)	3.52 (89.4)	3.33 (84.6)	6.12 (155.5)	8.00 (3.63)
TPV-2FM	113245	2" Female NPT	2" Male NPT	2.06 (52.3)	4.65 (118.1)	5.85 (148.6)	8.87 (225.3)	2.00 (50.8)	4.00 (101.6)	3.52 (89.4)	3.33 (84.6)	6.12 (155.5)	8.00 (3.63)

*All dimensions +/- 0.125 (3.2 mm) tolerance. Dimensions are subject to change. Not to be used for construction purposes unless certified.

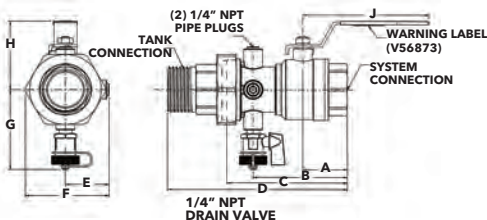

These valves are not recommended to be used on potable water tanks.

HEAT EXCHANGERS Brazed Plate Heat Exchangers

Description

Model BPX brazed plate heat exchangers offer the highest level of thermal efficiency and durability in a compact, low cost unit. The corrugated plate design provides very high heat transfer coefficients, resulting in a more compact design. The unit's stainless steel plates are vacuum brazed together to form a durable, integral piece that can withstand high pressure and temperature.

The BPX heat exchangers offer a compact design compared to shell and tube exchangers

- 1/6 the size of shell and tube
- 1/5 the weight of shell and tube
- 1/8 the liquid required of shell and tube
- 1/3 to 1/5 of the surface area required

BPX units are ideal for a wide variety of hydronic applications such as:

- Radiant Floor Heating
- Domestic Water Heating
- Snow MELT Systems
- Swimming Pool Heating

Operating Data

Design Pressure: 435 PSI (30 bar)
Design Temperature: 450°F (232°C)
Plates: Stainless Steel
Braze Material: Copper and Nickel Option
Connections: From 1/2 inch to 4 inch
Capacity: Up to 800 GPM
Construction Codes : UL, CRN, ASME Code Stamp Option



Also available in double-wall design.

Designed for dependability – Small size. Big impact.

Mechanical Design:

Design pressures up to 435 PSIG.
Maximum design temperature up to 450°F. Minimum design temperature to -310°F.

Construction Codes:

Available codes include UL, CRN, and ASME code stamp.

Materials:

Stainless steel 316L plates.
Copper and Nickel brazed material.



Connections:

From 1/2 inch to 4 inch. Standard connection options include NPT, SAE flanged and sweat. Custom connections available.

Capacity:

Up to 800 GPM and 350 sq.ft. of surface area.

Mounting:

Reduce mounting costs with optional threaded studs or integral mounting bracket.



HEAT EXCHANGERS Brazed Plate Heat Exchangers

Quick Selection Tables

Domestic Water Heating							
Boiler Side: Water 180° F supply, 130° F return Domestic Water Side: Water 50° F supply, 140° F return							
Model	Heat Exchanged BTU/Hr	Boiler Side		Domestic Water Side		B&G Pump Selection ¹	Pipe Size ^{††}
		Flow GPM	Pressure Drop PSI	Flow GPM	Pressure Drop PSI		
BP400-10 (¾" MPT)	60,000	2.5	1.6	1.3	0.3	NBF-9U	¾"
BP400-20 (¾" MPT)	150,000	6.2	2.1	3.3	0.6	NBF-9U	¾"
BP400-30 (¾" MPT)	225,000	9.3	2.2	5.0	0.7	NBF-9U	1"
BP400-40 (¾" MPT)	350,000	14.4	3.4	7.8	1.0	NBF-12	1¼"
BP410-30 (1" MPT)	450,000	18.6	6.2	10.0	1.8	NBF-25	1½"
BP410-40 (1" MPT)	600,000	24.8	6.2	13.3	2.0	NBF-25	1½"
BP410-50 (1" MPT)	800,000	33.0	6.9	17.8	2.4	NBF-25	1½"
BP410-60 (1" MPT)	900,000	37.1	6.9	20.0	2.2	NBF-25	2"
BP410-80 (1" MPT)	1,100,000	45.4	6.8	24.4	2.2	NBF-36	2"
BP423-30 (2" MPT)	1,500,000	61.9	4.6	33.3	1.4	NBF-45	2"
BP423-40 (2" MPT)	2,000,000	82.5	4.6	44.4	1.4	PL-45B	2½"
BP423-50 (2" MPT)	2,500,000	103.1	4.8	55.5	1.5	PL-75B	2½"

Larger models are available upon request. † Assumptions: 200 ft. TEL of copper pipe with (6) 90 degree elbows. †† Pipe size shown is not the connection size of the heat exchanger.

Domestic Water Heating - Double Wall							
Boiler Side: Water 180° F supply, 130° F return Domestic Water Side: Water 50° F supply, 140° F return							
Model	Heat Exchanged BTU/Hr	Boiler Side		Domestic Water Side		B&G Pump Selection [†]	Pipe Size ^{††}
		Flow GPM	Pressure Drop PSI	Flow GPM	Pressure Drop PSI		
BPDW410-20 (1" MPT)	60,000	2.5	0.2	1.3	0.1	NBF-9U	5/8"
BPDW410-34 (1" MPT)	150,000	6.2	0.4	3.3	0.1	NBF-9U	3/4"
BPDW415-24 (1" MPT)	225,000	9.3	3.8	5.0	0.9	NBF-9U	1"
BPDW415-34 (1" MPT)	350,000	14.4	4.5	7.8	1.1	NBF-12	1-1/4"
BPDW415-40 (1" MPT)	450,000	18.6	5.4	10.0	1.4	NBF-25	1-1/4"
BPDW422-20 (2" MPT)	600,000	24.8	5.5	13.3	1.3	NBF-25	1-1/2"
BPDW422-30 (2" MPT)	800,000	33.0	4.1	17.8	1.1	NBF-25	1-1/2"
BPDW422-34 (2" MPT)	900,000	37.1	4.0	20.0	1.1	NBF-25	2"
BPDW422-40 (2" MPT)	1,100,000	45.4	4.2	24.4	1.2	NBF-36	2"
BPDW422-50 (2" MPT)	1,500,000	61.9	5.0	33.3	1.4	NBF-45	2"
BPDW422-70 (2" MPT)	2,000,000	82.5	4.7	44.4	1.4	PL-45B	2-1/2"

† Assumptions: 20 ft. of copper pipe with (6) 90 degree elbows. †† Pipe size shown isn't the connection size of the heat exchanger.

Snow Melt Applications							
Boiler Side: Water 180° F supply, 160° F return Snow Side: Water 40% P.G. 100° F supply, 130° F return							
Model	Heat Exchanged BTU/Hr	Boiler Side		Snow Melt Side		B&G Pump Selection [†]	Pipe Size ^{††}
		Flow GPM	Pressure Drop PSI	Flow GPM	Pressure Drop PSI		
BP400-10 (¾" MPT)	30,000	3.1	2.4	2.1	0.9	NRF-25	¾"
BP400-10 (¾" MPT)	45,000	4.6	5.1	3.2	2.1	NRF-35	¾"
BP400-14 (¾" MPT)	60,000	6.2	4.2	4.3	1.9	NRF-25	1"
BP400-20 (¾" MPT)	100,000	10.3	5.4	7.1	2.7	NRF-36	1"
BP400-40 (¾" MPT)	175,000	18.0	5.2	12.5	2.8	NRF-36	1½"
BP412-30 (1" MPT)	250,000	25.8	4.1	17.9	2.1	PL-36	1½"
BP412-30 (1" MPT)	300,000	30.9	5.8	21.4	2.9	PL-55	2"
BP412-50 (1" MPT)	450,000	46.4	6.2	32.1	3.3	613	2"
BP424-20 (2" MPT)	600,000	61.8	4.8	42.9	2.8	609	2"
BP424-30 (2" MPT)	900,000	92.7	4.8	64.3	3.0	614	2½"
BP424-40 (2" MPT)	1,200,000	123.6	5.1	85.7	3.2	625	3"
BP424-50 (2" MPT)	1,350,000	139.1	4.7	96.4	2.9	625	3"

Larger models are available upon request. † Assumptions: Longest radiant loop is 250 ft. PEX. †† Pipe size shown isn't the connection size of the heat exchanger.

Outdoor Wood Boiler					
Boiler Side: Water 180° F supply, 155° F return House Side: Water 140° F supply, 165° F return					
Model	Heat Exchanged BTU/Hr	Boiler Side		House Side	
		Flow GPM	Pressure Drop PSI	Flow GPM	Pressure Drop PSI
BP400-20LP (¾" MPT)	30,500	2.52	0.4	2.5	0.3
BP400-30LP (¾" MPT)	50,000	4.12	0.5	4.1	0.4
BP400-40LP (¾" MPT)	70,000	5.77	0.6	5.7	0.6
BP410-20LP (1" MPT)	80,000	6.60	1.9	6.5	1.6
BP410-30LP (1" MPT)	130,000	10.72	2.2	10.6	1.92
BP410-40LP (1" MPT)	179,500	14.80	2.3	14.6	2.2
BP410-50LP (1" MPT)	229,500	18.92	2.5	18.7	2.4
BP410-60LP (1" MPT)	279,000	23.00	2.8	22.8	2.6
BP410-70LP (1" MPT)	329,000	27.13	3.0	26.8	2.9
BP410-80LP (1" MPT)	378,500	31.21	3.3	30.9	3.2
BP410-90LP (1" MPT)	428,500	35.33	3.7	34.9	3.6
BP410-100LP (1" MPT)	478,000	39.41	4.0	39.0	4.0

Larger models are available upon request.

Swimming Pool Heating						
Boiler Side: Water 180° F supply, 130° F return Pool Side: Water 70° F supply, 107° F return						
Model ³	Pool Size Gallons ¹	Heat Exchanged BTU/Hr	Boiler Side		Pool Side	
			Flow GPM	Pressure Drop PSI	Flow ² GPM	Pressure Drop PSI
BP400-10 (¾" MPT)	2,000	33,300	1.37	0.5	1.8	0.6
BP400-10 (¾" MPT)	6,000	99,900	4.10	4.1	5.4	5.0
BP400-20 (¾" MPT)	8,000	133,200	5.50	1.7	7.3	2.5
BP400-30 (¾" MPT)	15,000	250,234	10.00	2.7	14.0	4.5
BP412-20 (1" MPT)	20,000	333,645	13.00	2.5	18.0	3.4
BP412-20 (1" MPT)	30,000	500,467	20.70	5.6	27.2	7.7
BP412-30 (1" MPT)	40,000	667,290	27.00	3.9	36.0	6.9
BP424-20 (2" MPT)	60,000	1,000,936	40.00	2.3	54.0	3.6
BP424-30 (2" MPT)	80,000	1,334,581	53.00	1.9	72.0	3.1
BP424-40 (2" MPT)	100,000	1,668,226	67.00	2.8	90.0	4.7
BP424-40 (2" MPT)	120,000	2,001,871	82.50	2.5	108.0	4.2
BP424-50 (2" MPT)	150,000	2,502,000	103.20	2.7	135.6	4.7

Larger models are available upon request. 1) Provides approx. 2° F per hour heating with 180° F boiler to achieve 80° F pool temperature. 2) Pool water flow rate usually requires flow by pass from main pool circulation. 3) Chlorinated pool water can be corrosive to SS316L and Copper. Proper control of chlorine levels is required or alternate materials of construction should be considered.

Radiant Floor Heating							
Boiler Side: Water 180° F supply, 160° F return Radiant Floor Side: Water 100° F supply, 120° F return							
Model	Heat Exchanged BTU/Hr	Boiler Side		Radiant Floor Side		B&G Pump Selection [†]	Pipe Size ^{††}
		Flow GPM	Pressure Drop PSI	Flow GPM	Pressure Drop PSI		
BP400-10 (¾" MPT)	30,000	3.1	2.4	3.0	1.6	NRF-25	¾"
BP400-10 (¾" MPT)	50,000	5.2	6.1	5.0	4.2	NRF-36	1"
BP400-20 (¾" MPT)	100,000	10.3	5.2	10.1	4.4	NRF-36	1½"
BP400-30 (¾" MPT)	150,000	15.5	5.3	15.2	4.9	NRF-36	1½"
BP400-40 (¾" MPT)	200,000	20.6	5.8	20.2	5.5	NRF-36	1½"
BP411-20 (1" MPT)	250,000	25.8	3.3	25.2	3.0	PL-36	2"
BP411-20 (1" MPT)	350,000	36.1	6.3	35.3	5.6	PL-55	2"
BP411-30 (1" MPT)	450,000	46.4	6.1	45.4	5.8	607	2"
BP424-20 (2" MPT)	600,000	61.8	4.8	60.6	4.2	609	2½"
BP424-30 (2" MPT)	900,000	92.7	4.8	90.9	4.5	611	3"
BP424-40 (2" MPT)	1,200,000	123.6	5.1	121.2	5.0	625	3"
BP424-50 (2" MPT)	1,350,000	139.1	4.7	136.3	4.6	619	3"

Larger models are available upon request. † Assumptions: Longest radiant loop is 200 ft. PEX. †† Pipe size shown isn't the connection size of the heat exchanger.

Service and support from the most trusted name in the industry – Bell & Gossett.

The Bell & Gossett name has always stood for uncompromising quality and dependability. That's evident in the way every one of our centrifugal pumps is built and backed by our outstanding customer service and support team.

Your local Bell & Gossett representative is available any time and is an experienced professional with a wealth of technical expertise. In addition to expert system and product application assistance and a wide product inventory warehoused locally, we offer ESP-Systemwise software selection program.



ESP-Systemwise is a Bell & Gossett web-based software that helps you design HVAC systems accurately, effectively and very quickly. You get fast, precise equipment selection, pump performance curves and equipment schedules, submittals, specifications replacement parts and more.

ESP-Systemwise includes:

- Centrifugal Pumps
- Air/Dirt Separators
- Drives and Controls
- Expansion Tanks
- Heat Exchangers
- PIC Valves
- Replacement Parts
- Suction Diffuser and Triple Duty Valve
- Wastewater/Stormwater

The Little Red Schoolhouse® - Training the Industry



Bell & Gossett has long been known for its dedication to training. The "Little Red Schoolhouse®" has graduated over 60,000 students since it was founded in 1954.

Graduates from the "Little Red Schoolhouse" may be found throughout North America, Europe, Africa, Asia and Australia.

For applications to attend these seminars, please contact a Bell & Gossett Representative in your area. They will have the schedule dates for all seminars and will make all the arrangements for you. As a service and a continuing educational source to the HVAC industry, these seminars are offered free of charge. IACET certified CEU credits are awarded for each seminar.

Seminars currently offered are:

- Modern Hydronic System Design – Basic*
- Modern Hydronic System Design – Advanced*
- Design & Application of Water Based HVAC Systems
- Large Chilled Water System Design*
- Pump Service & Maintenance School
- Steam Systems Design & Applications
- Steam System Operation & Maintenance
- Plumbing Systems Design

* The USGBC has approved the technical and instructional quality of the Modern Hydronic Heating Systems - Basic Seminar (15 GBCI CE Hours) and the Large Chilled Water Design Seminar (11 GBCI CE Hours). These courses are approved for GBCI Continuing Education Hours towards LEED Credential Maintenance Programs.



We value your feedback. Please take our 3 question survey at bellgossett.com/survey to let us know how we are doing.



Xylem Inc.
8200 N. Austin Avenue
Morton Grove, Illinois 60053
Phone: (847) 966-3700
Fax: (847) 965-8379
www.xylem.com/bellgossett