

- 225°F maximum working temperature, 175 PSI maximum working pressure
- Close-coupled, horizontal or vertical installation
- Space saving, low maintenance, long life, quick shipment
- For hydronic heating and cooling, pressure boosting, industrial fluid transfer, refrigeration and heat exchanger circulation

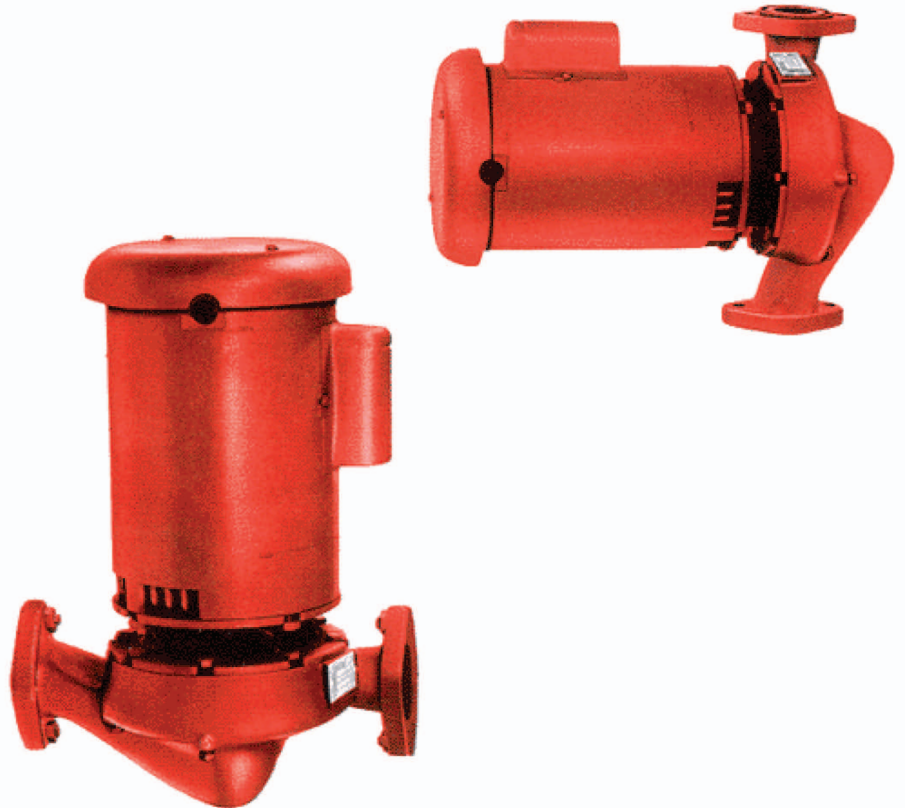

# Series 90 In-Line Mounted Centrifugal Pumps

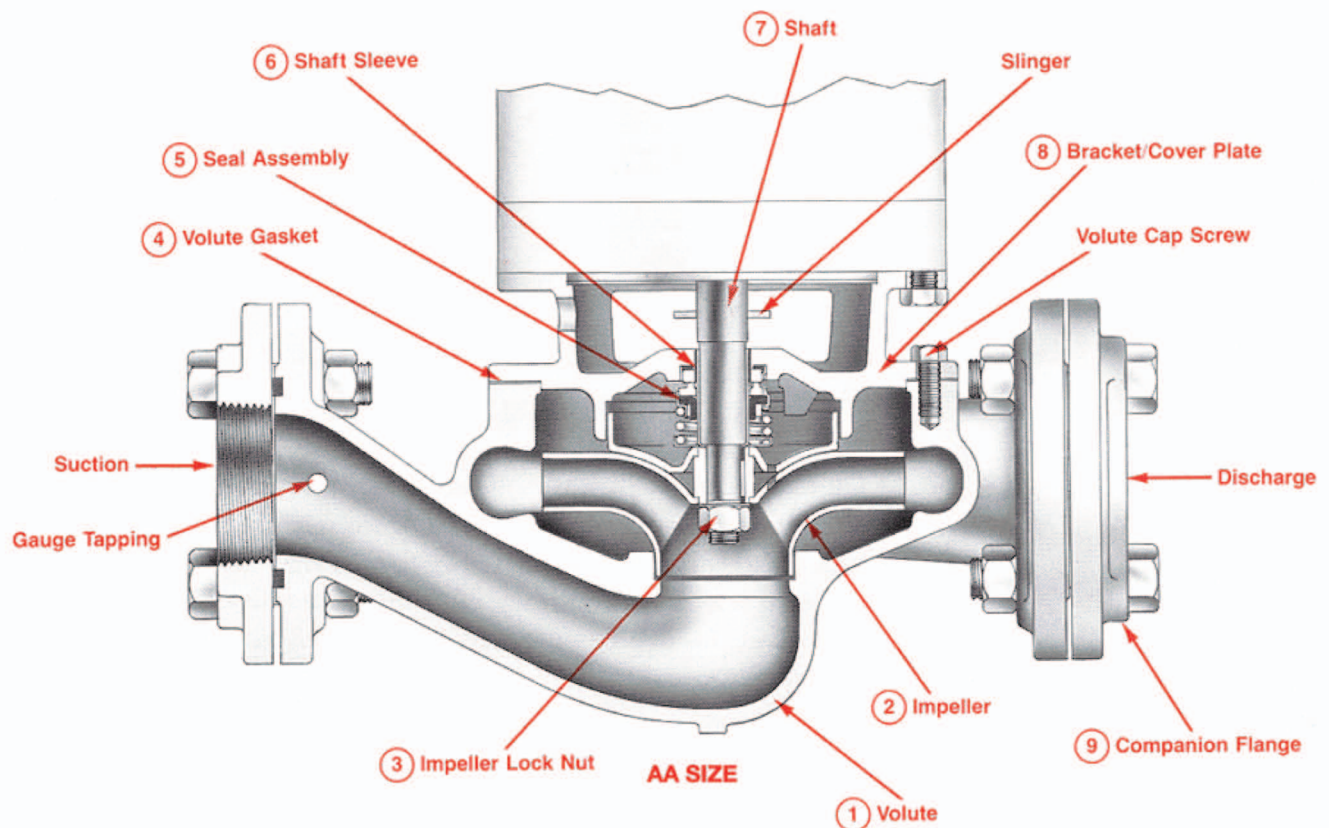
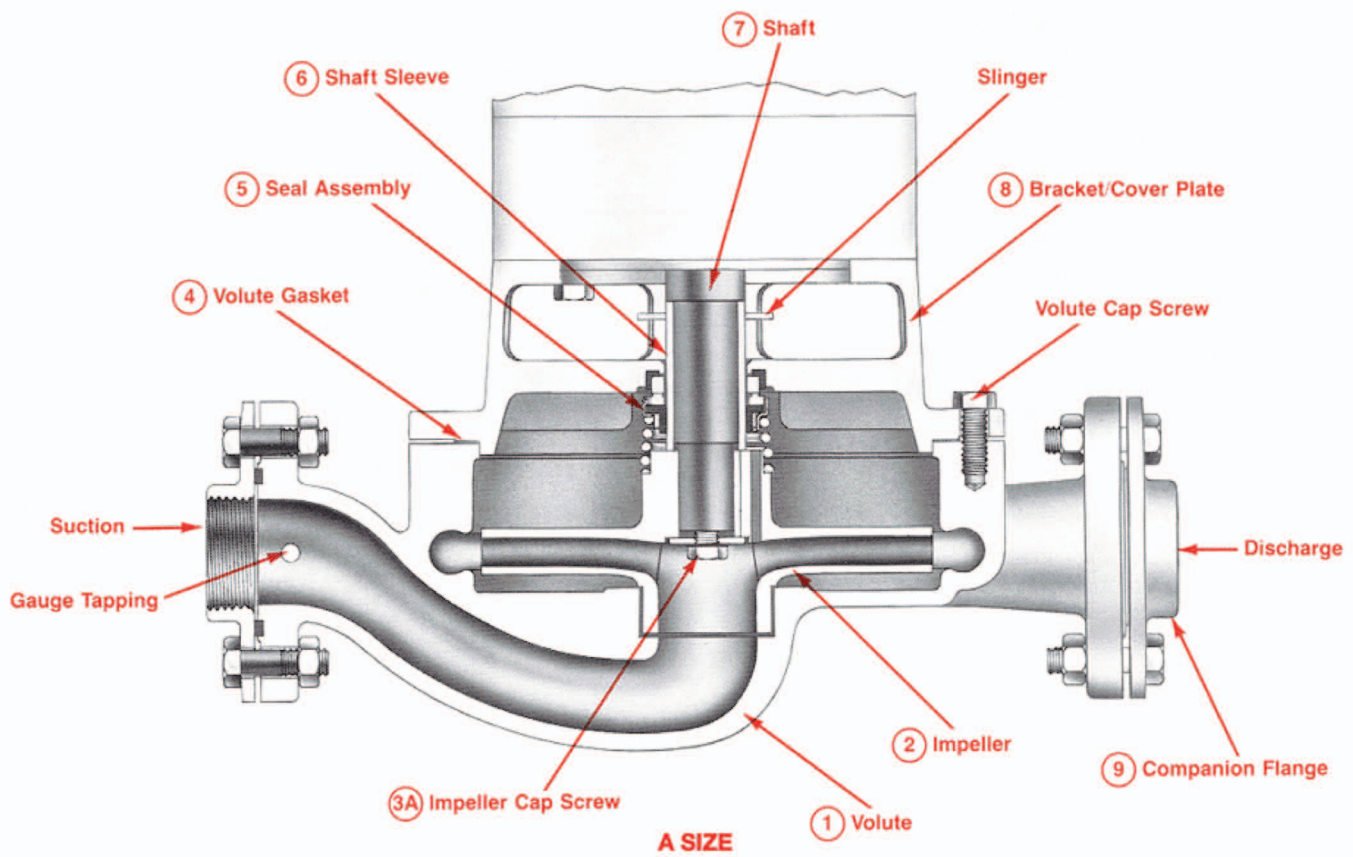

## Construction Materials for parts in contact with fluid

ITEM NO.	DESCRIPTION	BRONZE FITTED PUMP	ALL BRONZE PUMP*
1	Volute	Cast Iron ASTM #A159	Cast Brass ASTM #B584
2	Impeller	AA Sizes – Brass ASTM #B36 A Sizes – Cast Brass ASTM #B584	
3	Impeller Lock Nut	#304 Stainless Steel	#304 Stainless Steel
3A	Impeller Capscrew	#304 Stainless Steel	#304 Stainless Steel
4	Volute Gasket	Cellulose Fiber	Cellulose Fiber
5	Seal Assembly Seal Housing Bellows Seal Ring Spring Seat Insert Seat Gasket	Brass Buna N Rubber Carbon #304 Stainless Steel Ceramic Buna N Rubber	
6	Shaft Sleeve	All except 7 $\frac{1}{2}$ , 10, & 15 HP Sizes – Copper Alloy 110 7 $\frac{1}{2}$ , 10, & 15 HP Sizes – Aluminum Bronze – ASTM #B198	
7	Shaft	#1045 Steel	#1045 Steel
8	Bracket	Cast Iron ASTM #A159	Cast Brass ASTM #B584
9	Companion Flange	1", 1 $\frac{1}{4}$ ", 1 $\frac{1}{2}$ " – Steel SAE1006 2" – Cast Iron ASTM #A150	1", 1 $\frac{1}{4}$ ", 1 $\frac{1}{2}$ " – Brass ASTM #B36 2" – Cast Brass ASTM #B584

\*Available in all sizes  $\frac{1}{2}$  through 5 HP ratings only.

## Series 90 Centrifugal Pumps

Bronze fitted construction — companion flanges furnished.  
Standard Mechanical Seal

**Maximum Working Pressure 175 PSI**

Motors: 115/230 V, Single Phase or  
208-230/460 V, Three Phase  
60 Hz  
ODP

# Selection Charts

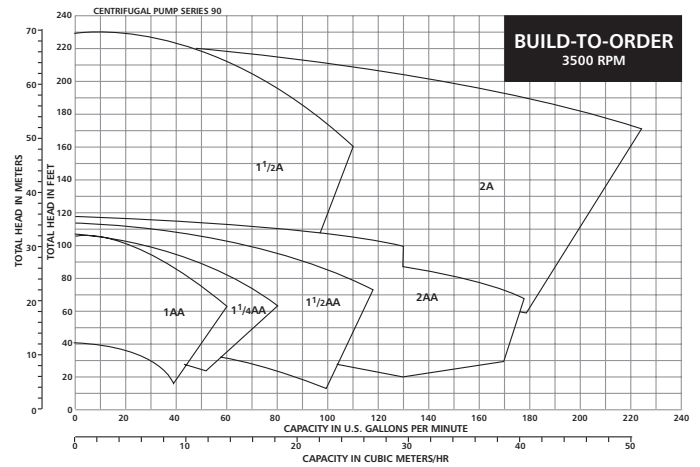
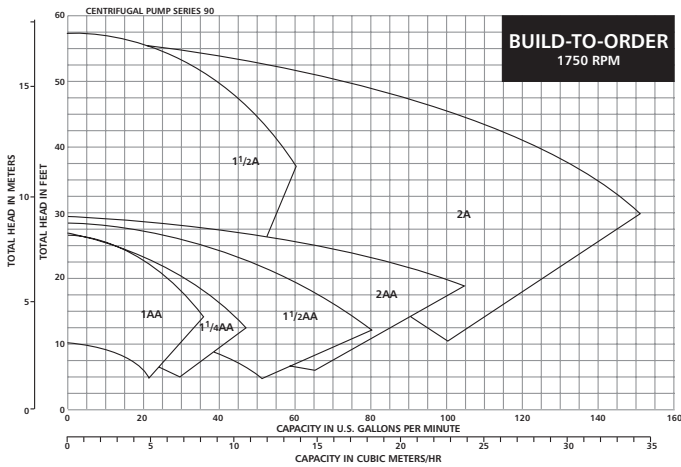
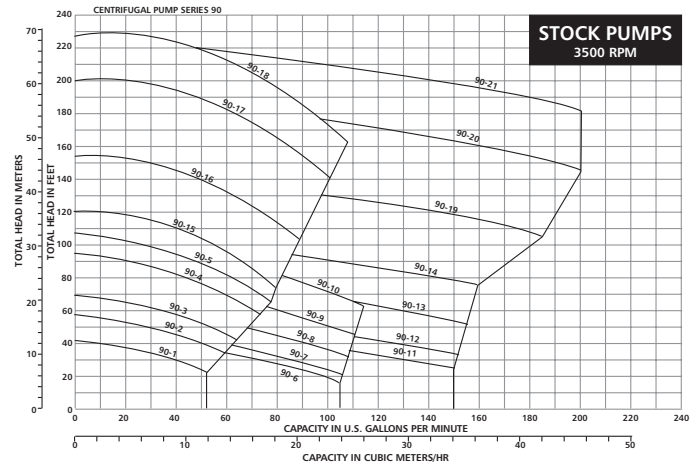
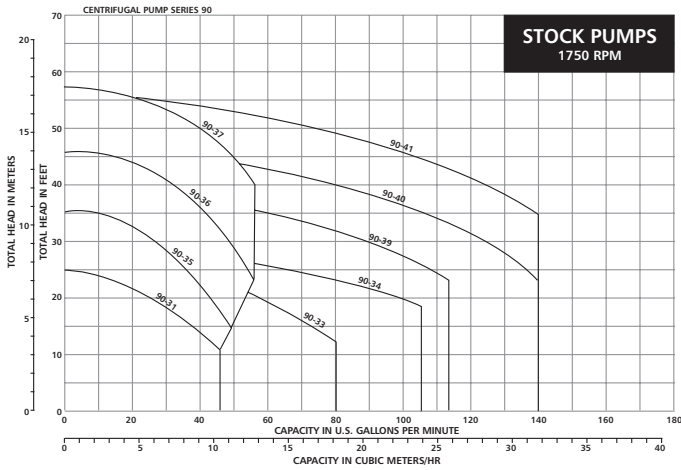

**Add "S" to pump number when ordering single phase pumps.**  
**Add "T" to pump number when ordering three phase pumps.**

# Series 90 Centrifugal Pumps ...

## A perfect solution to your pumping needs

**Ease of Selection** A total of 16 single phase and 30 three phase units are available and provide excellent coverage for a large range of pumping requirements. In addition, all pumps can be built to order for more precise pump selection.

**Ease of Installation** In-Line mounting saves space and alleviates need for special mounting blocks, pads or foundations. Ordinary piping support is all that is needed. Additionally, the Series 90 may be installed vertically or horizontally.

**Ease of Maintenance** Back pull-out design. Piping need not be disturbed for disassembly. These pumps are very easily serviced. Units 5 HP and smaller are furnished with sealed for life ball bearings. The 7½, 10 and 15 HP units are furnished with fittings for regreasing at recommended intervals.

**Typical Specifications** Furnish and install pumps with capacities as shown on plans. Pumps shall be in-line type, close-coupled, single stage design, for installation in vertical or horizontal position, and capable of being serviced without disturbing piping connections.

Pump volute shall be of Class 30 cast iron, and impeller shall be of bronze/brass, enclosed type, keyed and secured to the shaft by a locking capscrew or nut.

The liquid cavity shall be sealed off at the motor shaft by an internally-flushed mechanical seal with ceramic seal seat and carbon seal ring, suitable for continuous operation at 225°F. A shaft sleeve shall completely cover the wetted area under the seal.

Pumps shall be rated for maximum of 175 psi working pressure. Casings shall have gauge ports at nozzles, and vent and drain ports in casing.

Motor shall meet NEMA specifications and shall be the size, voltage and enclosure called for on the plans. It shall have heavy-duty grease lubricated ball bearings, completely adequate for the maximum load for which the motor is designed.

Each pump shall be factory tested. It shall then be thoroughly cleaned and painted with at least one coat of high-grade machinery enamel prior to shipment.

Pump shall be Series "90" as manufactured by Bell & Gossett.

# Series "90" Dimensional Drawings

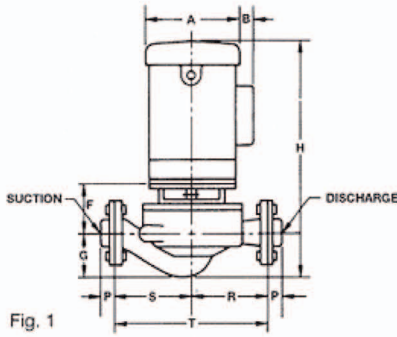

Fig. 1

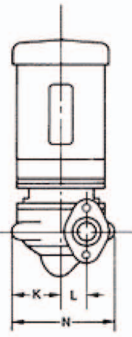

Fig. 2

## 3500 RPM FIG. 1

STOCK MODEL NO.	PUMP SIZE	SUCTION & DISCHARGE SIZE NPT	MOTOR H.P.	PHASE	NO. OF FLANGE BOLTS	DIMENSIONS - IN INCHES (MM)																						
						MAX. A	B	F	G	MAX. H	K	L	N	P	R	S	T											
—	1AA	1	1/2	1	2	7 1/2 (191)	1 1/2 (38)	2 1/2 (70)	3 3/4 (94)	16 (406)	3 (76)	1 1/2 (38)	6 1/2 (156)	—	—	—												
				3			15 1/2 (397)																					
				1			16 1/2 (419)																					
			3	16 1/2 (413)																								
			1	17 1/2 (451)																								
			1 1/2	17 1/2 (438)																								
2	17 1/2 (451)																											
3	—	—	—	—	—	—	—	—	—	—	—	—	—	—	—													
90-1S	1 1/2 AA	1 1/2	1/2	1	7 1/2 (191)	1 1/2 (38)	2 1/2 (73)	3 3/4 (98)	15 1/2 (394)	3 1/2 (92)	1 1/2 (35)	7 1/2 (191)	1/2 (19)	—	—	—												
3			15 1/2 (384)																									
1			16 (406)																									
3			15 1/2 (397)																									
1			16 1/2 (419)																									
3			16 1/2 (413)																									
1			17 1/2 (451)																									
1 1/2			17 1/2 (438)																									
2			17 1/2 (451)																									
3			—	—		—			—								—	—	—	—	—	—	—	—	—	—	—	
90-6S	1 1/2 AA	1 1/2	1/2	1	7 1/2 (191)	1 1/2 (38)	2 1/2 (73)	3 3/4 (98)	16 1/2 (413)	3 1/2 (92)	1 1/2 (35)	7 1/2 (200)	—	—	—	—												
3			15 1/2 (403)																									
1			16 1/2 (425)																									
3			16 1/2 (419)																									
1			17 1/2 (451)																									
1 1/2			17 1/2 (438)																									
2			17 1/2 (451)																									
3			—	—		—			—								—	—	—	—	—	—	—	—	—	—		
90-8S			1 1/2 AA	1 1/2		1			1								7 1/2 (191)	1 1/2 (38)	2 1/2 (73)	3 3/4 (98)	18 (457)	3 1/2 (92)	1 1/2 (35)	7 1/2 (200)	—	—	—	—
3						17 1/2 (445)																						
1	18 (457)																											
3	18 1/2 (464)																											
1	19 1/2 (495)																											
1 1/2	19 1/2 (495)																											
2	—	—			—	—	—	—	—	—	—	—	—	—	—	—												
90-9T	2AA	2			1/2	1	7 1/2 (191)	1 1/2 (38)	3 (76)	4 (102)	18 1/2 (464)	3 (76)	1 1/2 (35)	8 (203)	7/16 (21)	—		—			—							
3					17 1/2 (451)																							
1					18 1/2 (464)																							
3			18 1/2 (464)																									
1			19 1/2 (502)																									
1 1/2			19 1/2 (502)																									
2			—	—	—	—		—			—						—		—	—		—	—	—	—	—		
90-10T			2AA	2	1	1		7 1/2 (191)			1 1/2 (38)						3 (76)		4 (102)	18 1/2 (464)		3 (76)	1 1/2 (35)	8 (203)	7/16 (21)	—	—	—
3					17 1/2 (451)																							
1					18 1/2 (464)																							
3	18 1/2 (464)																											
1	19 1/2 (502)																											
1 1/2	19 1/2 (502)																											
2	—	—			—	—	—		—	—	—	—	—	—	—	—		—										
90-11S	2AA	2			1/2	1	7 1/2 (191)		1 1/2 (38)	3 (76)	4 (102)	18 1/2 (464)	3 (76)	1 1/2 (35)	8 (203)	7/16 (21)		—		—	—							
3					17 1/2 (451)																							
1					18 1/2 (464)																							
3			18 1/2 (464)																									
1			19 1/2 (502)																									
1 1/2			19 1/2 (502)																									
2			—	—	—	—		—	—			—					—		—			—	—	—	—	—		
90-12T			2AA	2	1	1		7 1/2 (191)	1 1/2 (38)			3 (76)					4 (102)		18 1/2 (464)			3 (76)	1 1/2 (35)	8 (203)	7/16 (21)	—	—	—
3					17 1/2 (451)																							
1					18 1/2 (464)																							
3	18 1/2 (464)																											
1	19 1/2 (502)																											
1 1/2	19 1/2 (502)																											
2	—	—			—	—	—		—	—	—		—	—	—	—		—	—									
90-13T	2AA	2			1/2	1	7 1/2 (191)		1 1/2 (38)	3 (76)	4 (102)		18 1/2 (464)	3 (76)	1 1/2 (35)	8 (203)		7/16 (21)	—	—	—							
3					17 1/2 (451)																							
1					18 1/2 (464)																							
3			18 1/2 (464)																									
1			19 1/2 (502)																									
1 1/2			19 1/2 (502)																									
2			—	—	—	—		—	—			—	—				—					—	—	—	—	—		
90-14T			2AA	2	1	1		7 1/2 (191)	1 1/2 (38)			3 (76)	4 (102)				18 1/2 (464)					3 (76)	1 1/2 (35)	8 (203)	7/16 (21)	—	—	—
3					17 1/2 (451)																							
1					18 1/2 (464)																							
3	18 1/2 (464)																											
1	19 1/2 (502)																											
1 1/2	19 1/2 (502)																											
2	—	—			—	—	—		—	—	—			—	—	—	—	—	—									

## 3500 RPM FIG. 2

STOCK MODEL NO.	PUMP SIZE	SUCTION & DISCHARGE SIZE NPT	MOTOR H.P.	PHASE	FRAME	NO. OF FLANGE BOLTS	DIMENSIONS - IN INCHES (MM)															
							MAX. A	F	G	MAX. H	J	K	L	N	P	R	S	T				
90-15T	1 1/2 A	1 1/2	3	3	56C	2	7 1/2 (191)	3 3/4 (94)	3 1/2 (89)	18 1/2 (470)	—	4 1/2 (117)	1 (25)	9 1/2 (241)	1/2 (19)	6 1/2 (165)	7 (178)	13 1/2 (343)				
90-16T			5				11 1/2 (298)	4 1/2 (116)		20 (508)									23 1/2 (594)	3 1/2 (89)	27 1/2 (695)	4 1/2 (105)
90-17T			7 1/2				14 (356)	4 7/8 (124)		20 1/2 (514)									—	—	—	—
90-18T			10				7 1/2 (191)	3 3/4 (94)		20 1/2 (514)									—	—	—	—
—	2A	2	5	3	56	4	7 1/2 (191)	3 3/4 (94)	3 1/2 (89)	20 1/2 (514)	—	4 1/2 (121)	1 (25)	9 1/2 (251)	1/2 (21)	—	7 1/2 (191)	14 (356)				
90-19T			7 1/2				11 1/2 (298)	4 1/2 (116)		23 1/2 (600)									3 1/2 (86)	27 1/2 (695)	4 (102)	
90-20T			10				14 (356)	4 7/8 (124)		23 1/2 (600)									3 1/2 (86)	27 1/2 (695)	4 (102)	
90-21T			15				7 1/2 (191)	3 3/4 (94)		20 1/2 (514)									—	—	—	—

All single phase motors include built-in thermal overload protectors. Bronze fitted construction — companion flanges furnished for suction and discharge. Motors — open dripproof enclosure. Single phase — unit no. ending in "S" 115/230 volt cycle 1 phase. Three phase — unit no. ending "T" 208-230/460 volt 60 cycle 3 phase.

**MAXIMUM WORKING PRESSURE 175 PSI.**

Dimensions are approximate. Not to be used for construction purposes unless certified.



# Xylem |'zīləm|

- 1) The tissue in plants that brings water upward from the roots;
- 2) a leading global water technology company.

We're 12,500 people unified in a common purpose: creating innovative solutions to meet our world's water needs. Developing new technologies that will improve the way water is used, conserved, and re-used in the future is central to our work. We move, treat, analyze, and return water to the environment, and we help people use water efficiently, in their homes, buildings, factories and farms. In more than 150 countries, we have strong, long-standing relationships with customers who know us for our powerful combination of leading product brands and applications expertise, backed by a legacy of innovation.

**For more information on how Xylem can help you, go to [www.xyleminc.com](http://www.xyleminc.com)**



Xylem Inc.  
8200 N. Austin Avenue  
Morton Grove, Illinois 60053  
Phone: (847) 966-3700  
Fax: (847) 965-8379  
[www.xyleminc.com/brands/bellgossett](http://www.xyleminc.com/brands/bellgossett)

Bell & Gossett is a trademark of Xylem Inc. or one of its subsidiaries.  
© 2012 Xylem Inc. B-112E October 2000