



Hoffman Specialty® Model 78 and 79

Industrial and Commercial Water Main Vent Valves for Hydronic Heating and Cooling Applications

Built-In Check Valve

A unique feature of Hoffman Specialty air vents, which assures the air you want to eliminate from the system does not get back in when system pressures fall.

Glycol Ready

Brass and stainless steel construction of Hoffman Specialty air vents assures long life in glycol environments, with no chance of material breakdown.

High Capacity

Vents up to 850 SCIM. The only vent in this category with published ratings.

Top Mounted, Replaceable Seat

Seat and check valve are above the shell, isolated from suspended dirt in the system. Removable seat and check valve assembly allows quick cleaning or replacement.

Convenient Threaded Inlets and Outlets

Air outlets on both models are equipped with a 1/8" NPT thread, allowing connection of a piped drain where any water leakage is unacceptable. The Model 79 is supplied with both 1/2" female and 3/4" male NPT connections for great flexibility in application and installation. Model 78 has 3/4" male NPT connection.

System and Application Assistance

Hoffman Specialty Vents come with one feature unmatched by any other supplier, your local Bell & Gossett Representative. Your representative can provide the assistance to make certain your entire system will perform as expected.



Model 78



Model 79

Air Vent Suggested Specifications

1.0 PIPING DETAILS

- 1.1** Furnish and install air vents as shown on the detail drawings. Air vents are to be installed at all high points in the system and on all air separating devices.
- 1.2** Air vents are installed above the outlet connection using a minimum of 3/4" pipe.
- 1.3** A ball type shut-off with line size port is installed in the connection pipe to allow servicing without draining the system.
- 1.4** The vent outlet is piped to a drain using minimum size 1/4" copper tubing. On Glycol systems, the vent discharge is piped to a recovery unit.

2.0 AIR VENTS

- 2.1** Select the air vent that has an operating pressure higher than the maximum system operating pressure.
- 2.2** The vent discharge is equipped with a ball check valve to prevent re-entry of air if the system pressure should drop below atmospheric pressure.
- 2.3** Air vent housings have brass bodies and brass or stainless steel floats.
- 2.4** The inlet connection is equipped with an anti-siphon device to allow free entry of air.
- 2.5** Air vents are rated for maximum 250°F (120°C) operating temperature.
- 2.6** Air vents are suitable for use on water or glycol systems.
- 2.7** Model 78 vents should be used for systems with maximum operating pressures up to 150 psi (10.3 bar)
Model 79 vents should be used for systems with maximum operating pressures up to 75 psig (5.2 bar)

Dimensions

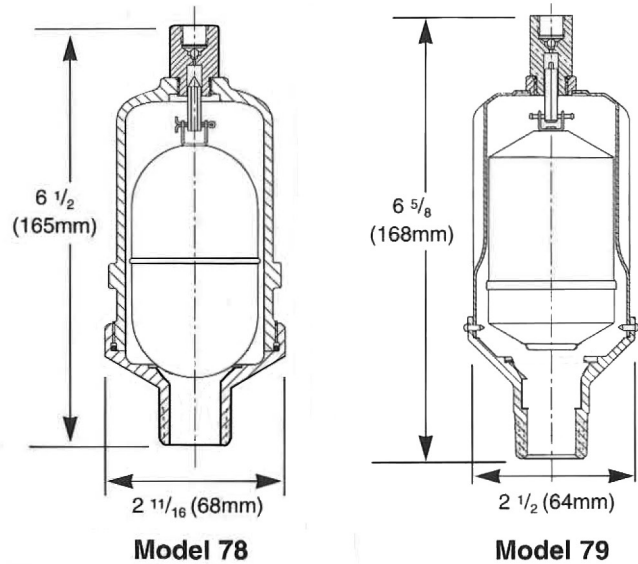

Capacities

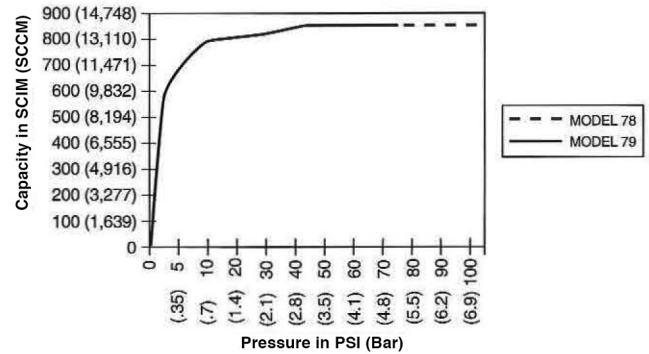

Ordering Information

Model No.	Part No.
78	401485
79	401488

Ratings					
Model	NPT Inlet Size in. (mm)	NPT Outlet Size in. (mm)	Maximum Operating Pressure psig (bar)	Maximum Hydrostatic Pressure psig (bar)	Maximum Operating Temperature °F (°C)
78	3/4 (20) male	1/8 (4)	150 (10.3)	450 (31.1)	250 (121)
79	1/2 (15) female	1/8 (4)	75 (5.2)	200 (13.8)	250 (121)
	3/4 (20) male				



Xylem Inc.
8200 N. Austin Avenue
Morton Grove, Illinois 60053
Phone: (847) 966-3700
Fax: (847) 965-8379
www.bellgossett.com